

ULTRA-DEX™

by ARCHi™

FOR **\$159**

Kit includes Milling Cutter
and 10 inserts

35% SAVINGS
OFF LIST PRICE!

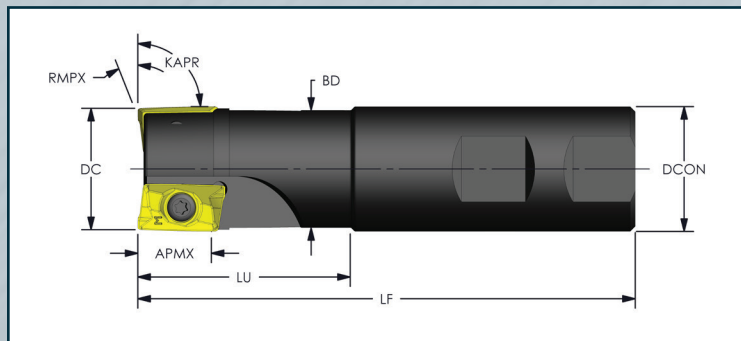

OPTION 1:
E90AP D.750-3-W.750-11 KIT

1X E90AP D.750-3-W.750-11
10X APKT 11T308-PM UD404

OPTION 2:
E90AP D1.00-3-W1.00-11 KIT

1X E90AP D1.00-3-W1.00-11
10X APKT 11T308-PM UD404

DESIGNATION	DC	APMX	ZEFF	LU	BD	KAPR	RMPX	LF	DCON
E90AP D.750-3-W.750-11	.750	.433	3	.975	.705	90	5°	3.375	.750
E90AP D1.00-3-W1.00-11	1.000	.433	3	1.50	.955	90	4.5°	4.000	1.000

Find out more about our other
Tool holding products [here](#)

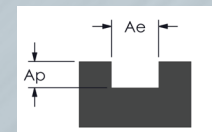
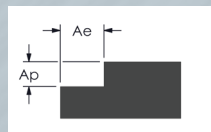

	CUTTING PARAMETERS (SFM)	Hardness HB	SQUARE SHOULDER MILLING			SLOT MILLING		
			SFM	Inch/Tooth	Ae	SFM	Inch/Tooth	Ae
P	Non Alloyed Steel (0-.45% C)	≤ 180	1000 (650-1300)	.008 (.004-.012)	≤0.5D	600 (450-800)	.006 (.004-.010)	D
	Low Alloyed Steel	180-280	900 (600-1100)	.008 (.004-.012)	≤0.5D	550 (400-800)	.006 (.004-.010)	D
	High Alloyed Steel	280-350	850 (500-1100)	.008 (.004-.012)	≤0.5D	500 (360-800)	.006 (.004-.010)	D
M	Stainless Steel	≤ 270	650 (360-1000)	.008 (.004-.012)	≤0.5D	400 (260-600)	.006 (.004-.010)	D
S	Heat Resistant Steels	200	150 (100-300)	.008 (.004-.012)	≤0.5D	150 (100-300)	.006 (.004-.010)	D

Request or download Ultra-Dex catalog at ARCHCUTTINGTOOLS.COM

OFFER VALID: JANUARY 1ST - MARCH 31ST 2020

Choose from three Coolant-Thru Steel Boring Bar kits today! Each kit comes with 10 High Performance inserts

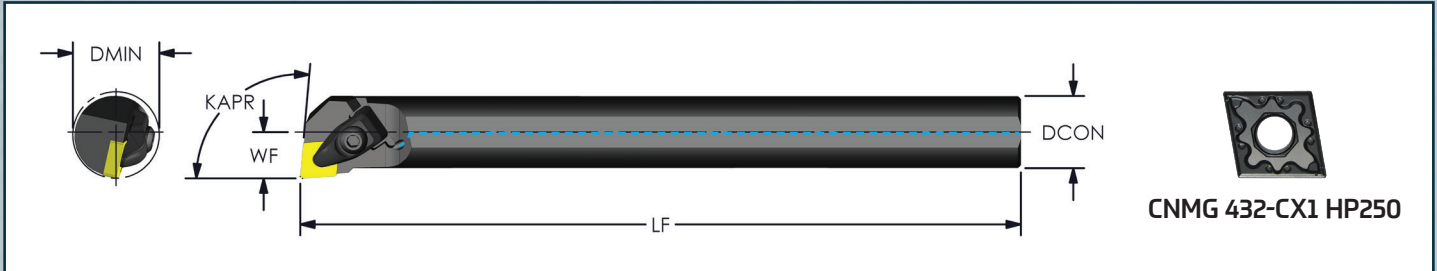

\$230 **OPTION 1:**
A16S DCLNR4 KIT
1X A16S DCLNR4
10X CNMG 432-CX1 HP250

\$250 **OPTION 2:**
A20U DCLNR4 KIT
1X A20U DCLNR4
10X CNMG 432-CX1 HP250

\$330 **OPTION 3:**
A24U DCLNR4 KIT
1X A24U DCLNR4
10X CNMG 432-CX1 HP250

40% SAVINGS OFF LIST PRICE!

DESIGNATION	DCON	LF	WF	KAPR	DMIN	INSERT	SHIM	SHIM SCREW	CLAMP ASM
A16S DCLNR4	1.000	10	.640	95	1.200	CNMG 432	-	-	PB4-CA
A20U DCLNR4	1.250	14	.765	95	1.470		ICSN 433	PB4-SS	
A24U DCLNR4	1.500	14	.890	95	1.730		ICSN 433	PB4-SS	

***High performance inserts for steel, stainless steel and cast iron**

	HP250	Universal steel turning grade	.009-.017 In/Rev .039-.157 ap (Inch)
	CUTTING PARAMETERS (SFM)		Hardness HB
P	Non Alloyed Steel (0-.45% C)		150-200
	Low Alloyed Steel		250-300
	High Alloyed Steel		200
	Corrosion Resistance Steel		200
M	Ferritic		200
	Austenitic		180
	Duplex		230-260
	Martensitic		330
K	Grey Cast Iron		180
	Ductile Cast Iron		160
	Malleable Cast Iron		130

Find out more about other Boring Bar products [here](#)

Request or download Ultra-Dex catalog at ARCHCUTTINGTOOLS.COM