



VG-Cut

Complete Range of Turning Solutions



INCH
METRIC

GROOVEX

Innovative Grooving & Turning Solutions

VG-Cut | Complete Range of Turning Solutions

Deep Grooving, Threading, Parting Off, Boring and Face Grooving

VARGUS Ltd., the leading supplier of premium thread turning and thread milling solutions, as well as hand deburring tools, launched its groundbreaking range of GROOVEX tool solutions for cost-effective, high-performance grooving applications in 2011.

With full commitment to the GROOVEX line of tooling and insert solutions across all industry sectors, VARGUS Ltd. is pleased to introduce its newest family of products - the VG-Cut.

The new family of VG-Cut tools opens doors to greater application exposure within the same insert pocket of Deep Grooving, Parting Off, Turning, Profiling, Boring, Face Grooving and Threading. The VG-Cut inserts offer excellent designated chip formers and carbide grades, making VG-Cut the most versatile product yet.

VG-Cut tools cover a wide range of Threading Standards for machining between shoulders and close to the spindle in up to shoulder depth of 10.0 mm.

The VG-Cut, with its unique multifunctional geometry, minimizes inventory for the end-user in an extensive selection of applications.

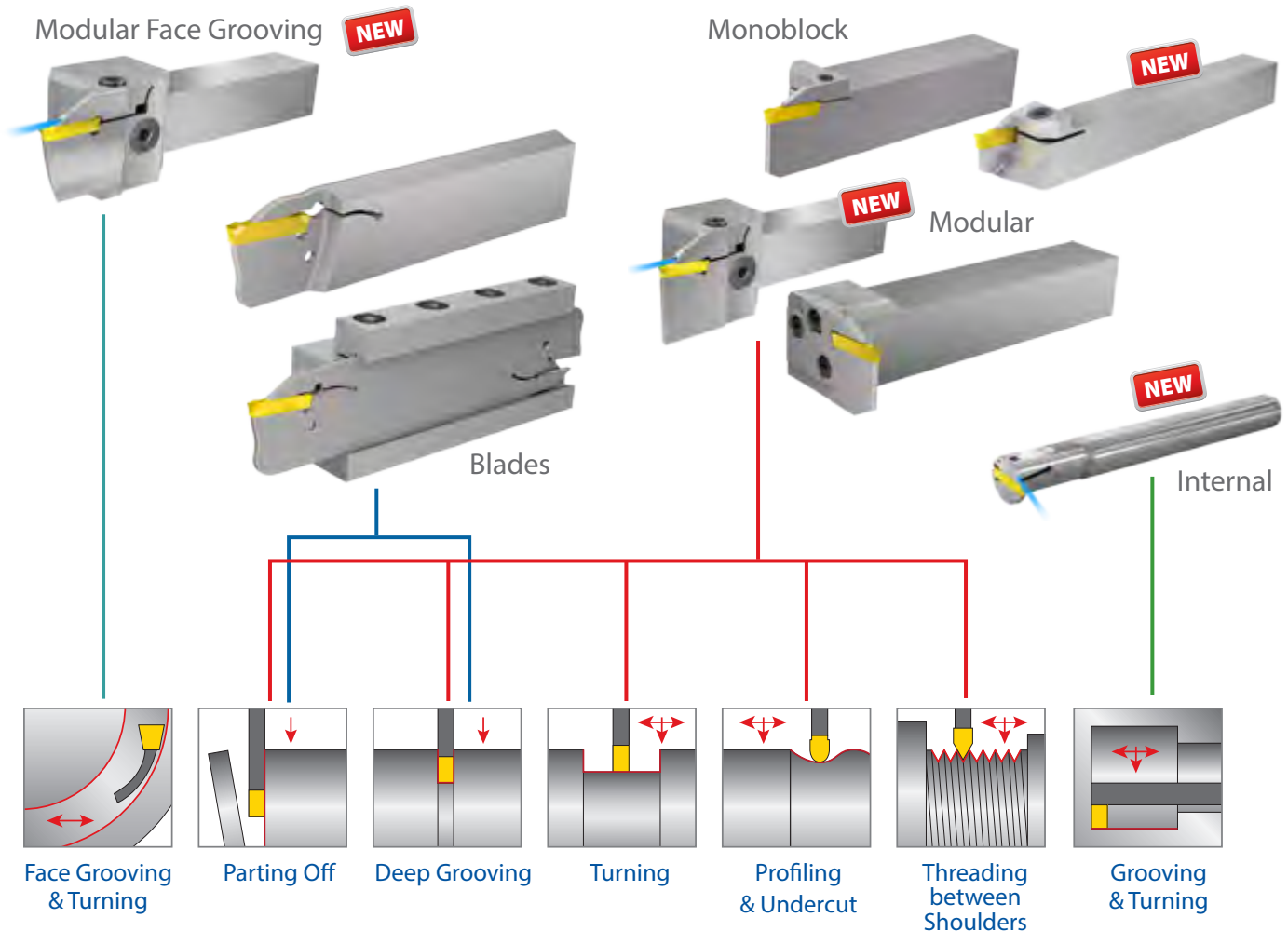

VG-Cut

■ VG-Cut Ordering Code System	Page 4
■ Insert, Tool and Cutting Data Selection Guide	Page 5

INSERTS

■ Parting Off & Deep Grooving - Double Sided Inserts (2.0-6.0 mm Width)	Page 8
■ Parting Off & Deep Grooving - Single Sided Inserts (2.0-4.0 mm Width)	Page 9
■ Turning & Profiling (2.0-6.0 mm Width)	Page 10
■ Threading (3.0 mm Width)	Page 11

TOOLS

■ External Monoblock Tools for Grooving, Parting Off, Turning & Threading (Metric)	Page 12
■ External Monoblock Tools for Grooving, Parting Off, Turning & Threading (Inch)	Page 13
■ Reinforced Monoblock Tools for Parting, Grooving & Threading (Metric & Inch)	Page 14
■ Blades for Grooving & Parting Off (Metric & Inch)	Page 15
■ Reinforced Blades for Grooving & Parting Off (Metric & Inch)	Page 15
■ Blade Holders (Metric & Inch)	Page 16
■ Modules for Grooving, Parting Off & Turning (Metric & Inch)	Page 17
■ Modular Bodies for Grooving, Parting Off & Turning (Metric)	Page 18
■ Modular Bodies for Grooving, Parting Off & Turning (Inch)	Page 19
■ Radial Grooving Modules with Coolant Thru (Metric & Inch)	Page 20
■ Face Grooving Modules with Coolant Thru (Metric & Inch)	Page 21
■ Modular Bodies for Grooving, Face Grooving, Parting Off & Turning	Page 23
■ Internal Grooving & Turning	Page 24

TECHNICAL DATA

■ Recommended Cutting Speeds for Grooving & Turning	Page 25
■ Feed Rate Starting Point for Deep Grooving & Parting Off	Page 26
■ Feed Rate and Depth of Cuts for Axial Turning & Profiling	Page 27
■ Selecting the Correct Face Grooving Module	Page 28
■ Face Groove and Turn Machining Recommendations	Page 29
■ User Guide for Modular System	Page 30
■ Recommended Cutting Speeds for Threading	Page 31

VG-Cut Inserts Ordering Code

VG	D	3.00	020	6R	GP	VPG
1	2	3	4	5	6	7

1 – Line Name Deep Grooving & Parting Off	2 – Number of Cutting Corners D - Double S - Single	3 – Insert Width 2.0, 3.0, 4.0, 5.0, 6.0 mm	4 – Corner Radius 0.20 mm Threading Standard
5 – RH or LH (for Grooving) 4, 6, 15 Deg. RH or LH NONE - Neutral	5 – RH or LH (for Threading) RH Helix LH Helix	6 – Top Rake Geometry GP, GM, GT, GR RS - Close to right shoulder LS - Close to left shoulder	7 – Carbide Grade VPG, VMG, VKG

VG-Cut Tools Ordering Code

Monoblock Toolholders

VG	E	R	2525	3	T12	C
1	2	9	3	4	5	10

Blades

VG	P	32	4	D	C
1	6	7	4	8	10

Modules

VG	A	R	20	T25	4	S	C
1	2	9	7	5	4	8	10

Holders/Bodies



VB	A	R	2525	32	C
1	2	9	3	7	10

Internal Toolholders

VG	I	R	20-25	3	C
1	2	9	3	4	10



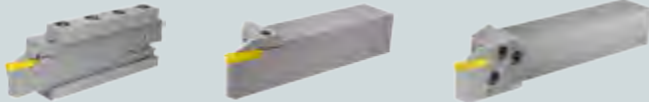

1 – Line Name VG - Deep Grooving & Parting Off VB - Holders	2 – Application E - External I - Internal A - Blades M - Modules	3 – For External Holders Shank Size	4 – Pocket Size 2, 3, 4
5 – Depth of Cut T12 - Limit Depth of Cut 12 mm	6 – Blade Type P - Universal A - Modules W - Reinforced blade	3 – For Internal Toolholders Shank Dia. - D min.	7 – Blade Height 20, 25, 26, 32 00, 45, 90 Approach angle
9 – RH or LH R - RH L - LH NON - Neutral	10 – Coolant C - Coolant	8 – Number of Pockets D - Double S - Single	

Insert, Tool and Cutting Data Selection Guide



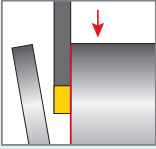

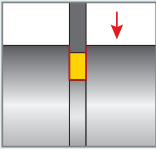

A	Identify the Application																																																						
B	Identify the Designated Work Piece Material	<table border="1"> <tr> <td style="background-color: #0070C0; color: white; text-align: center;">P Alloy Steel</td> <td style="background-color: #FFD700; color: black; text-align: center;">M Stainless Steel</td> <td style="background-color: #DC143C; color: white; text-align: center;">K Cast Iron</td> <td style="background-color: #3CB371; color: white; text-align: center;">N Non-Ferrous</td> <td style="background-color: #FF8C00; color: white; text-align: center;">S Heat Resistance</td> <td style="background-color: #808080; color: white; text-align: center;">H Hardened Material</td> </tr> </table>	P Alloy Steel	M Stainless Steel	K Cast Iron	N Non-Ferrous	S Heat Resistance	H Hardened Material																																															
P Alloy Steel	M Stainless Steel	K Cast Iron	N Non-Ferrous	S Heat Resistance	H Hardened Material																																																		
C	Designated Chip Former Geometry for Selected Applications		page 6																																																				
D	Designated Carbide Grade for Desired Application	<table border="1"> <tr> <td style="background-color: #808080; color: white; text-align: center;">VKG</td> <td style="background-color: #0070C0; color: white; text-align: center;">VPG</td> <td style="background-color: #FFD700; color: black; text-align: center;">VMG</td> </tr> </table>	VKG	VPG	VMG	page 7																																																	
VKG	VPG	VMG																																																					
E	Selecting Insert and Tool as Required by Operation		pages 8-24																																																				
F	Cutting Data According to Selected Items	<table border="1"> <tr> <td rowspan="3" style="background-color: #FFD700;">Stainless Steel</td> <td>15</td> <td>Stainless Steel</td> <td>Non-Hardened</td> <td>200</td> <td>50-120</td> <td>60-160</td> <td></td> </tr> <tr> <td>16</td> <td>Cast Ferritic</td> <td>Hardened</td> <td>330</td> <td>40-100</td> <td>50-140</td> <td></td> </tr> <tr> <td>17</td> <td>Stainless Steel</td> <td>Austenitic</td> <td>200</td> <td>50-120</td> <td>60-160</td> <td></td> </tr> <tr> <td rowspan="3" style="background-color: #DC143C;">Cast Iron</td> <td>18</td> <td>Cast Austenitic</td> <td>Hardened</td> <td>330</td> <td>40-100</td> <td>50-140</td> <td></td> </tr> <tr> <td>28</td> <td>Malleable</td> <td>Ferritic (short chips)</td> <td>130</td> <td></td> <td>160-280</td> <td>160-280</td> </tr> <tr> <td>29</td> <td>Cast Iron</td> <td>Pearlitic (long chips)</td> <td>230</td> <td></td> <td>140-220</td> <td>140-260</td> </tr> <tr> <td></td> <td>30</td> <td></td> <td>Low Tensile Strength</td> <td>180</td> <td></td> <td>160-240</td> <td>160-280</td> </tr> </table>	Stainless Steel	15	Stainless Steel	Non-Hardened	200	50-120	60-160		16	Cast Ferritic	Hardened	330	40-100	50-140		17	Stainless Steel	Austenitic	200	50-120	60-160		Cast Iron	18	Cast Austenitic	Hardened	330	40-100	50-140		28	Malleable	Ferritic (short chips)	130		160-280	160-280	29	Cast Iron	Pearlitic (long chips)	230		140-220	140-260		30		Low Tensile Strength	180		160-240	160-280	pages 25-31
Stainless Steel	15	Stainless Steel		Non-Hardened	200	50-120	60-160																																																
	16	Cast Ferritic		Hardened	330	40-100	50-140																																																
	17	Stainless Steel	Austenitic	200	50-120	60-160																																																	
Cast Iron	18	Cast Austenitic	Hardened	330	40-100	50-140																																																	
	28	Malleable	Ferritic (short chips)	130		160-280	160-280																																																
	29	Cast Iron	Pearlitic (long chips)	230		140-220	140-260																																																
	30		Low Tensile Strength	180		160-240	160-280																																																

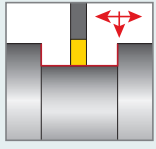

Designated Chip Former Geometry for Parting Off and Grooving

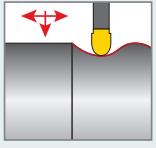
Application	Material Group	Standard Conditions	Extreme Conditions
 Parting Off	<div style="display: flex; justify-content: space-between;"> <div style="background-color: #0070C0; color: white; padding: 5px; text-align: center;"> P Alloy Steel </div> <div style="background-color: #A9A9A9; color: black; padding: 5px; text-align: center;"> H Hardened Material </div> </div> <div style="background-color: #D9534F; color: white; padding: 5px; text-align: center; margin-top: 5px;"> K Cast Iron </div>	 <p>GT Primary choice for machining alloy and stainless steel. Positive rake chip former leads to low cutting forces during cutting. A multifunctional chip former for parting, grooving and turning.</p>	 <p>GP Primary choice for machining cast iron, for interrupted cuts and for unstable applications where accuracy and overall machining stability are not clear. Reinforced cutting edge for parting off and grooving.</p>
	 Grooving	<div style="display: flex; justify-content: space-between;"> <div style="background-color: #FFD700; color: black; padding: 5px; text-align: center;"> M Stainless Steel </div> <div style="background-color: #FF8C00; color: black; padding: 5px; text-align: center;"> S Heat Resistance </div> </div> <div style="background-color: #32CD32; color: white; padding: 5px; text-align: center; margin-top: 5px;"> N Non-Ferrous </div> <div style="background-color: #0070C0; color: white; padding: 5px; text-align: center; margin-top: 5px;"> P Mild Steel </div>	 <p>GM/GF Primary choice for stainless steel. Positive sharp cutting edge decreases build-up on edge for parting off and grooving in low feeds.</p>

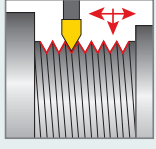
Designated Chip Former Geometry for Turning, Profiling and Threading

Application	Standard Conditions
 Turning	 <p>GT Primary choice for machining alloy and stainless steel. Positive rake chip former leads to low cutting forces during cutting, with multifunctional chip former for parting off, grooving and turning.</p>
 Profiling	 <p>GR Primary choice for grooving, undercut and profiling. Round shape geometric for profiling, and positive rake chip former with multifunctional chip control.</p>
 Threading	 <p>RS/LS Varied range of threading standards for machining between shoulders and close to the spindle.</p>

Designated Carbide Grade for Desired Application

Toughness vs. Hardness

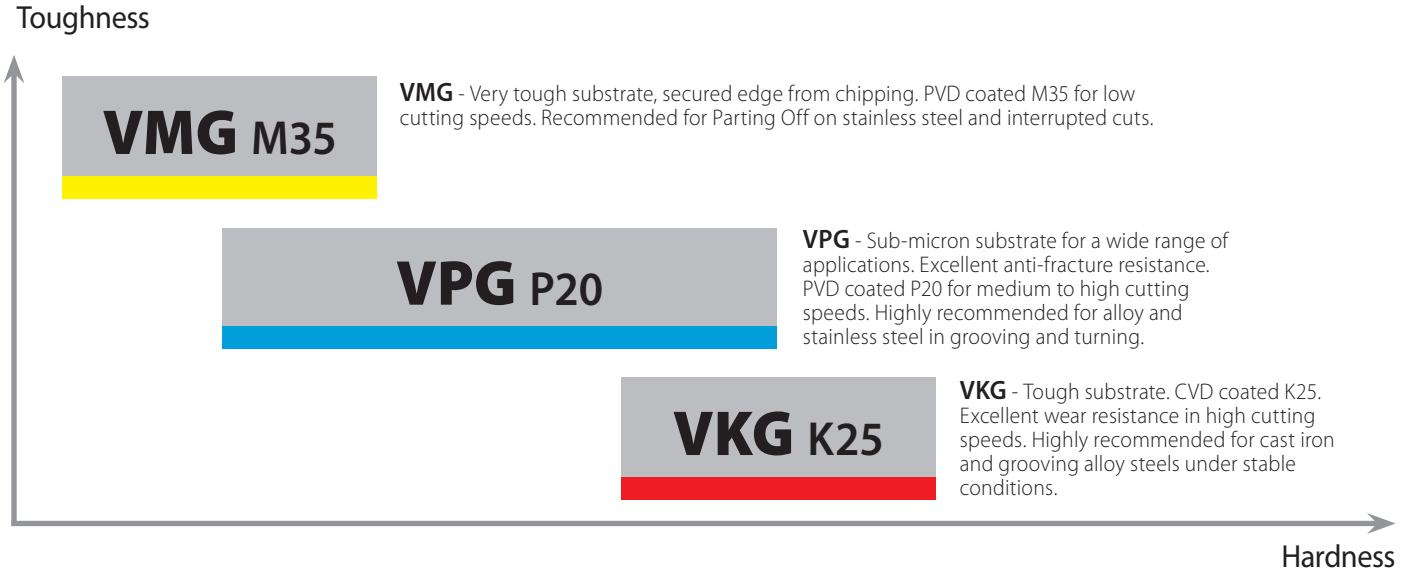

Recommended Carbide Grade for Designated Application

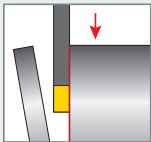
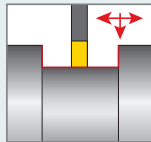
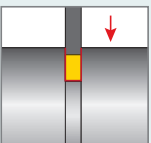
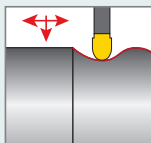
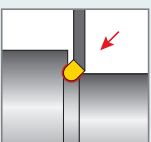
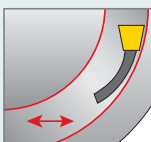
Application	Improved Chipping Resistance	Improved Wear Resistance	Application	Improved Chipping Resistance	Improved Wear Resistance
 Parting Off	VMG M35 ↔ VPG P20		 Turning	VPG P20 ↔ VKG K25	
 Grooving	VPG P20 ↔ VKG K25		 Profiling	VPG P20 ↔ VKG K25	
 Undercut	VMG M35 ↔ VPG P20		 Face Turning	VPG P20 ↔ VKG K25	

Parting Off & Deep Grooving - Double Sided Inserts

2.0 - 6.0 mm Width

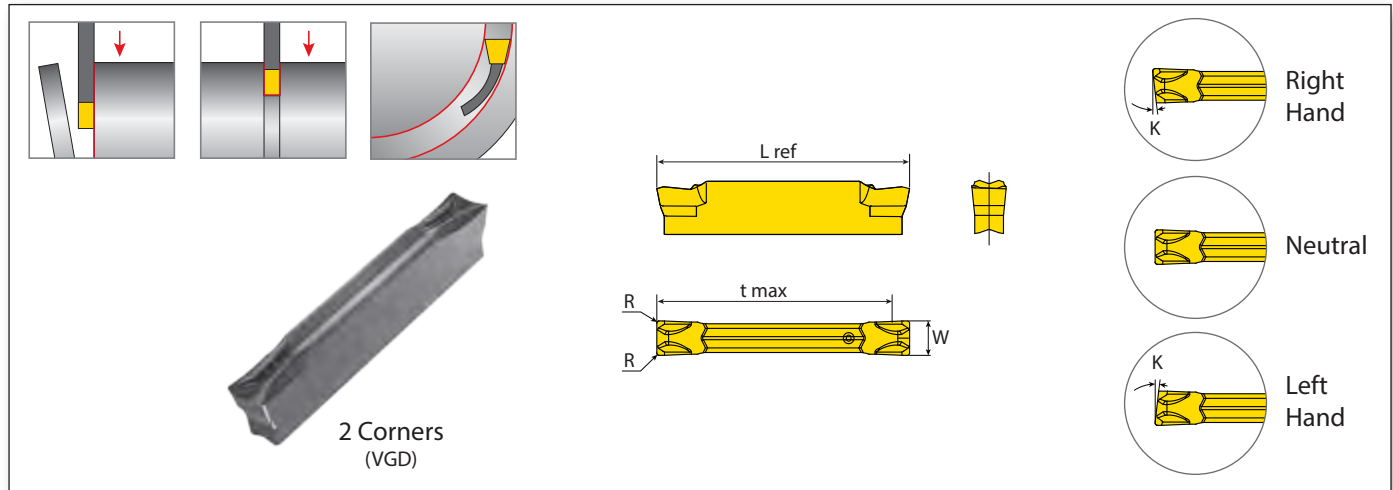

	Pocket Size	Ordering Code	Dimensions mm					Feed Range (mm/rev)	Grade			
			$W \pm 0.04$	R	t_{max}	K°	L_{ref}		VPG	VMG	VKG	
Positive cutting edge, for small parts, thin wall pipes & soft materials	GF	2	VGD2.00-020-GF	2.00	0.20	20.0	0.0	22.0	0.03 - 0.10	●	●	○
		2	VGD2.00-015-6R-GF	2.00	0.15	20.0	6.0	22.0	0.03 - 0.10	●	○	○
		2	VGD2.00-015-6L-GF	2.00	0.15	20.0	6.0	22.0	0.03 - 0.10	●	○	○
		2	VGD2.00-020-15R-GF	2.00	0.20	20.0	15.0	22.0	0.03 - 0.08	●	○	○
		2	VGD2.00-020-15L-GF	2.00	0.20	20.0	15.0	22.0	0.03 - 0.08	●	○	○
Positive sharp cutting edge, for low feed & speed	GM	3	VGD3.00-030-GM	3.00	0.30	20.0	0.0	22.0	0.08 - 0.22	●	●	●
		3	VGD3.00-020-6R-GM	3.00	0.20	20.0	6.0	22.0	0.05 - 0.16	○	●	○
		3	VGD3.00-020-6L-GM	3.00	0.20	20.0	6.0	22.0	0.05 - 0.16	○	●	○
		4	VGD4.00-040-GM	4.00	0.40	23.0	0.0	25.0	0.08 - 0.25	●	●	○
Multi-purpose geometric, for general use	GT	2	VGD2.00-020-GT	2.00	0.20	20.0	0.0	22.0	0.03 - 0.12	●	○	●
		3	VGD3.00-030-GT	3.00	0.30	20.0	0.0	22.0	0.05 - 0.15	●	○	●
		4	VGD4.00-020-GT	4.00	0.20	23.0	0.0	23.0	0.05-0.15	○	○	○
		4	VGD4.00-040-GT	4.00	0.40	23.0	0.0	25.0	0.05 - 0.18	●	○	●
		5	VGD5.00-040-GT	5.00	0.40	23.0	0.0	25.0	0.08 - 0.25	●	○	●
		6	VGD6.00-040-GT	6.00	0.40	23.0	0.0	25.0	0.10 - 0.25	●	○	●
Round multipurpose geometry for profiling & undercut	GR	2	VGD2.00-100-GR	2.00	1.00	18.0	0.0	22.0	0.03 - 0.12	●	○	○
		3	VGD3.00-150-GR	3.00	1.50	18.0	0.0	22.0	0.05 - 0.15	●	○	○
		4	VGD4.00-200-GR	4.00	2.00	20.0	0.0	25.0	0.05 - 0.18	●	○	○
Blunt reinforced cutting edge for high feed & speed	GP	2	VGD2.00-020-GP	2.00	0.20	20.0	0.0	22.0	0.03 - 0.14	●	○	●
		3	VGD3.00-020-GP	3.00	0.20	20.0	0.0	22.0	0.06 - 0.20	●	●	●
		3	VGD3.00-015-6R-GP	3.00	0.15	20.0	6.0	22.0	0.06 - 0.16	○	●	○
		3	VGD3.00-015-6L-GP	3.00	0.15	20.0	6.0	22.0	0.06 - 0.16	○	●	○
		4	VGD4.00-030-GP	4.00	0.30	23.0	0.0	25.0	0.08 - 0.24	●	●	●
		4	VGD4.00-020-4R-GP	4.00	0.20	23.0	4.0	25.0	0.06 - 0.22	○	●	○
		4	VGD4.00-020-4L-GP	4.00	0.20	23.0	4.0	25.0	0.06 - 0.22	○	●	○
		5	VGD5.00-040-GP	5.00	0.40	23.0	0.0	25.0	0.08 - 0.28	●	○	●
6	VGD6.00-040-GP	6.00	0.40	23.0	0.0	25.0	0.10 - 0.30	●	○	●		

- In stock
- Available upon request

Parting Off & Deep Grooving - Single Sided Inserts

2.0 - 4.0 mm Width

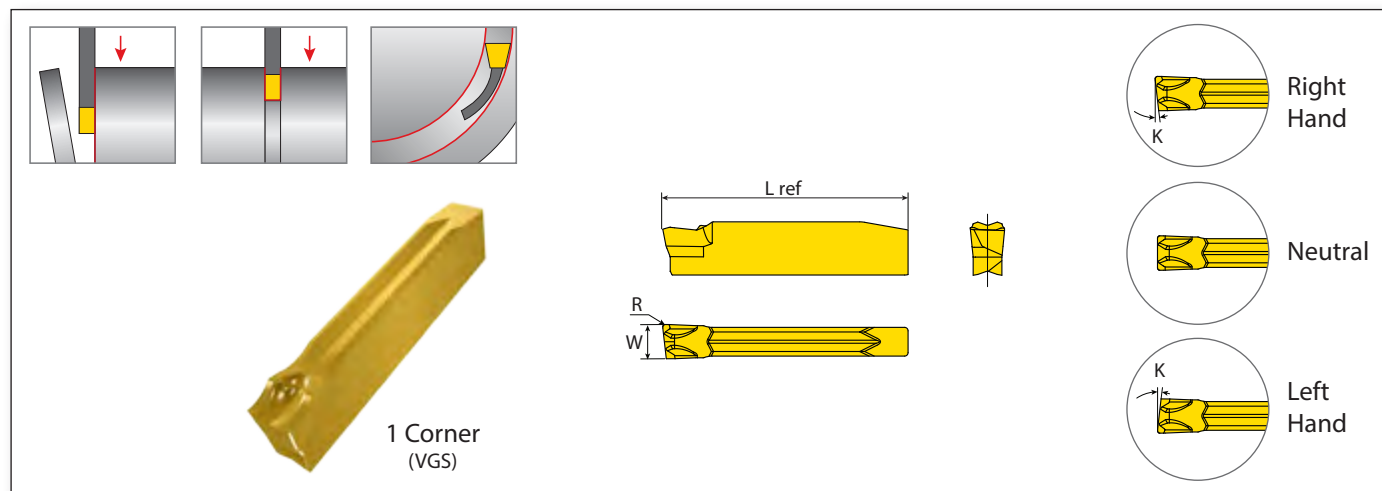

	Pocket Size	Ordering Code	Dimensions mm					Feed Range (mm/rev)			Grade		
			W ± 0.04	R	t max	K°	L ref	VPG	VMG	VKG			
Positive cutting edge, for small parts, thin wall pipes & soft materials	GF	2	VGS2.00-015-6R-GF	2.00	0.15	∞	6.0	21.3	0.03 - 0.10	○	●	○	
		2	VGS2.00-015-6L-GF	2.00	0.15	∞	6.0	21.3	0.03 - 0.10	○	●	○	
Positive sharp cutting edge, for low feed & speed	GM	3	VGS3.00-020-GM	3.00	0.20	∞	0.0	22.0	0.08 - 0.22	●	●	○	
		3	VGS3.00-020-6R-GM	3.00	0.20	∞	6.0	21.3	0.05 - 0.16	○	●	○	
		3	VGS3.00-020-6L-GM	3.00	0.20	∞	6.0	21.3	0.05 - 0.16	○	●	○	
		4	VGS4.00-040-GM	4.00	0.40	∞	0.0	25.0	0.08 - 0.25	●	●	○	
		4	VGS4.00-040-4R-GM	4.00	0.40	∞	4.0	24.3	0.06 - 0.18	○	●	○	
Blunt reinforced cutting edge for high feed & speed	GP	3	VGS3.00-020-GP	3.00	0.20	∞	0.0	22.0	0.06 - 0.20	●	●	○	
		3	VGS3.00-020-6R-GP	3.00	0.20	∞	6.5	21.3	0.06 - 0.16	○	●	○	
		3	VGS3.00-020-6L-GP	3.00	0.20	∞	6.5	21.3	0.06 - 0.16	○	●	○	
		4	VGS4.00-030-GP	4.00	0.30	∞	0.0	25.0	0.08 - 0.24	●	●	○	
		4	VGS4.00-030-4R-GP	4.00	0.30	∞	4.0	24.3	0.06 - 0.22	○	●	○	
4	VGS4.00-030-4L-GP	4.00	0.30	∞	4.0	24.3	0.06 - 0.22	○	●	○			

- In stock
- Available upon request

Turning & Profiling

2.0 - 6.0 mm Width

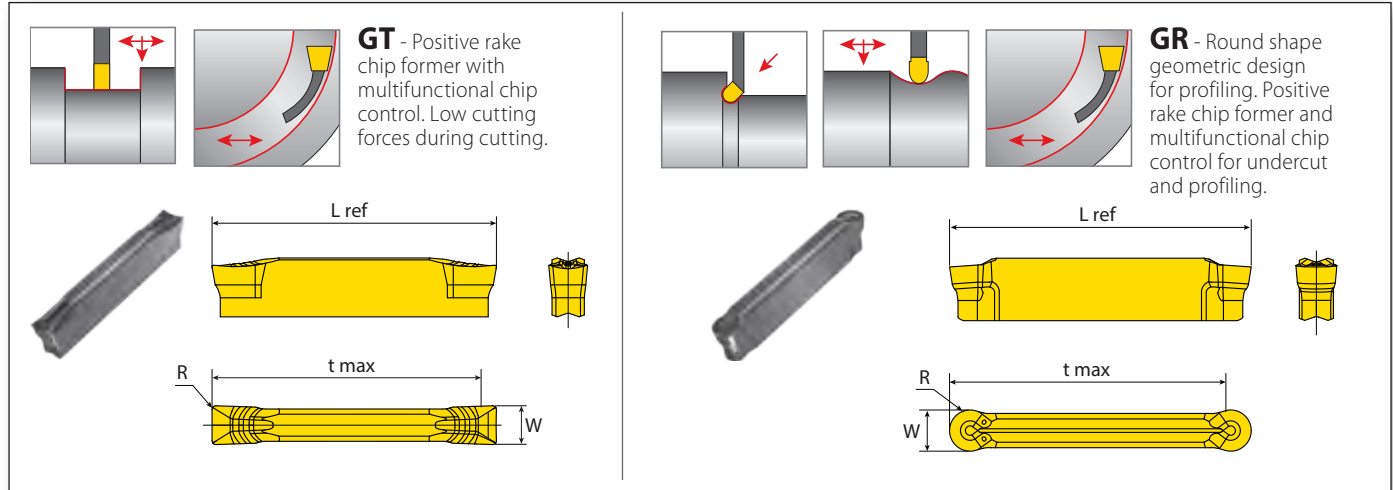

Pocket Size	Ordering Code	Dimensions mm				L ref	Feed Range (mm/rev)	Grade		
		W ± 0.05	R	t max	K°			VPG	VMG	VKG
2	VGD2.00-020-GT	2.00	0.20	20.0	-	22.0	0.05 - 0.10	●	○	●
3	VGD3.00-030-GT	3.00	0.30	20.0	-	22.0	0.05 - 0.25	●	○	●
4	VGD4.00-020-GT	4.00	0.20	23.0	-	25.0	0.05 - 0.18	○	○	○
4	VGD4.00-040-GT	4.00	0.40	23.0	-	25.0	0.08 - 0.28	●	○	●
5	VGD5.00-040-GT	5.00	0.40	23.0	-	25.0	0.08 - 0.25	●	○	●
6	VGD6.00-040-GT	6.00	0.40	23.0	-	25.0	0.10 - 0.28	●	○	●
2	VGD2.00-100-GR	2.00	1.00	18.0	-	22.0	0.06 - 0.12	●	○	○
3	VGD3.00-150-GR	3.00	1.50	18.0	-	22.0	0.06 - 0.18	●	○	○
4	VGD4.00-200-GR	4.00	2.00	20.0	-	25.0	0.06 - 0.20	●	○	○

- In stock
- Available upon request



Threading

3.0 mm Width

RS/LS Varied range of threading standards for machining between shoulders and close to spindle.

To be used with monoblock tools (VGE...T12) only

RS Full Profile

LS Full Profile

Partial Profile

Pocket Size	Ordering Code	Dimensions mm				No. of Passes	Helix	Grade	Min. Thread Diameter
		W ref	Pitch mm/tpi	h min	Y				
ISO Metric External Full Profile									
3	VGD3.0ISO0.50RH-RS/LS	3.00	0.50	0.31	0.53	5 - 7	2.5°	•	M3x0.5
3	VGD3.0ISO0.75RH-RS/LS		0.75	0.46	0.64	5 - 8		•	M5x0.75
3	VGD3.0ISO1.00RH-RS/LS		1.00	0.61	0.74	5 - 9		•	M6x1
3	VGD3.0ISO1.25RH-RS/LS		1.25	0.77	0.85	6 - 10		•	M8x1.25
3	VGD3.0ISO1.50RH-RS/LS		1.50	0.92	1.10	7 - 12		•	M10x1.5 Coarse
3	VGD3.0ISO1.75RH-RS/LS		1.75	1.07	1.20	8 - 14		•	M12x1.75 Coarse
3	VGD3.0ISO2.00RH-RS/LS		2.00	1.23	1.30	9 - 14		•	M16x2.0 Coarse
3	VGD3.0ISO2.50RH-RS/LS		2.50	1.53	1.55	8 - 14		•	M18x2.5 Coarse
American UN External Full Profile									
3	VGD3.0UN32RH-RS/LS	3.00	32	0.49	0.66	5 - 8	2.5°	•	5/32-32 UNC
3	VGD3.0UN28RH-RS/LS		28	0.56	0.71	5 - 9		•	3/16-28 UNC
3	VGD3.0UN24RH-RS/LS		24	0.65	0.77	5 - 9		•	7/32-24 UNC
3	VGD3.0UN20RH-RS/LS		20	0.78	0.86	6 - 10		•	1/4-20 UNC
3	VGD3.0UN18RH-RS/LS		18	0.87	0.93	7 - 12		•	5/16-18 UNC
3	VGD3.0UN16RH-RS/LS		16	0.97	1.10	7 - 12		◦	3/8-16 UNC
3	VGD3.0UN14RH-RS/LS		14	1.11	1.09	8 - 14		◦	7/16-14 UNC
3	VGD3.0UN12RH-RS/LS		12	1.30	1.30	8 - 14		◦	9/16-14 UNC
NPT External Full Profile									
3	VGD3.0NPT18RH-RS/LS	3.00	18	1.01	1.20	7 - 12	1.5°	•	1/4-18NPT
3	VGD3.0NPT14RH-RS/LS		14	1.33	1.40	8 - 14		•	1/2-14NPT
3	VGD3.0NPT11.5RH-RS/LS		12	1.64	1.60	9 - 15		◦	1-11.5NPT
Whitworth External Full Profile									
3	VGD3.0W19RH-RS/LS	3.00	19	0.86	0.95	7 - 12	2.5°	•	1/2-19BSW
3	VGD3.0W14RH-RS/LS		14	1.16	1.15	8 - 14		•	1/2-14BSW
3	VGD3.0W11RH/LH		11	1.48	1.68	8-14		•	5/8-11BSW

• In stock | ◦ Available upon request
LH Helix threads available upon request

External Partial Profile

Pocket Size	Ordering Code	Dimensions mm				No. of Passes	Helix	Grade	Min. Thread Diameter
		W ref	Pitch mm/tpi	R	Y				
3	VGD3.0A60RH	3.00	0.5-1.5	0.05	1.68	5 - 8	1.5°	•	Partial Profile A60
3	VGD3.0A55RH	3.00	48-16	0.05	1.68	5 - 8		•	Partial Profile A55

• In stock | ◦ Available upon request

External Monoblock Tools for Grooving, Parting Off, Turning & Threading | METRIC

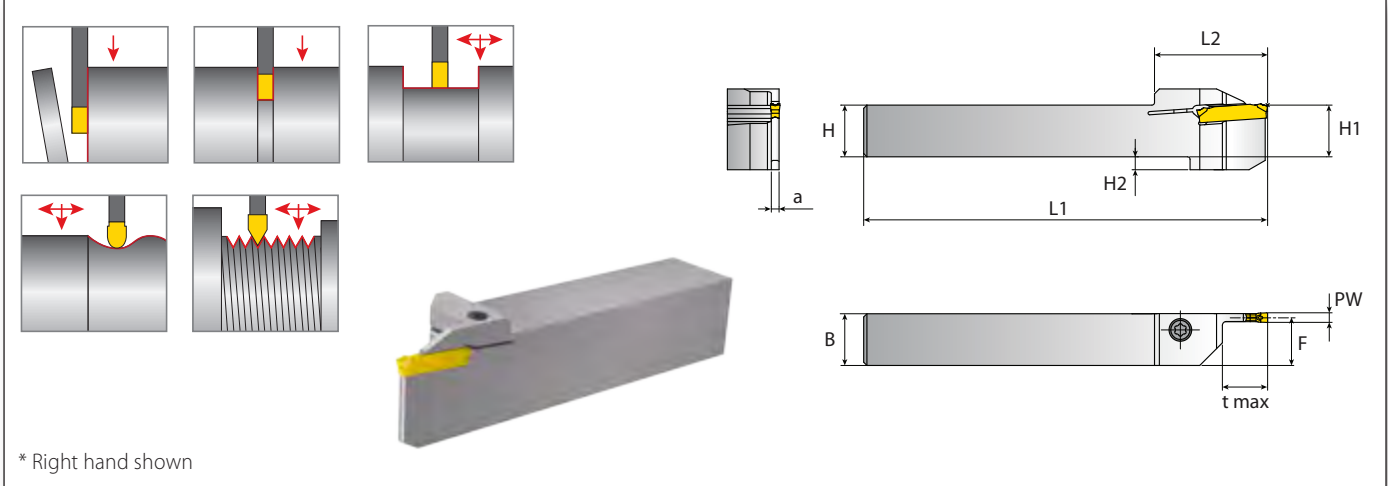

Metric Holders

Metric Holders										Spare Parts	
Ordering Code		Dimensions mm									
RH/LH	PW	t max	HXB	H1	F	L1	L2	a	H2	Cylindrical Screw	Key
VGER/L1616-2T12	2	12	16X16	16	15.3	125	35	1.4	4.0	SM4.0X16-T20	K6T
VGER/L2020-2T12			20X20	20	19.3	125	35	1.4	---		
VGER/L1212-3T12	3	12	12X12	12	10.8	125	35	2.4	4.0	SM3.5X14-T-15	KT-15
VGER/L1616-3T12			16X16	16	14.8	125	35	2.4	4.0		
VGER/L2020-3T12			20X20	20	18.8	125	35	2.4	---		
VGER/L2525-3T12			25X25	25	23.8	125	35	2.4	---		
VGER/L1616-3T21	4	21	16X16	16	14.8	125	35	2.4	4.0	SM4.0X18-T20	K6T
VGER/L2020-3T21			20X20	20	18.8	125	35	2.4	---		
VGER/L2525-3T21			25X25	25	23.8	125	35	2.4	---		
VGER/L2525-4T12			25X25	25	23.5	125	35	3.0	---		
VGER/L1616-4T21	5	22	16X16	16	14.5	125	35	3.0	4.0	SM6.0X20	K5H
VGER/L2020-4T21			20X20	20	18.5	125	35	3.0	---		
VGER/L2525-4T21			25X25	25	23.5	125	35	3.0	---		
VGER/L2525-5T22*			25X25	25	23.0	150	43	4.0	---		
VGER/L3232-5T22*	6	24	32X32	32	30.0	170	43	4.0	---	SM6.0X20	K5H
VGER/L2525-6T24*			25X25	25	22.5	150	45	5.0	---		
VGER/L3232-6T24*			32X32	32	29.5	170	45	5.0	---		

Mounting and Replacing Inserts for 5mm* & 6mm* Monoblock Toolholders:

1 Unlock the top screw using the key provided.

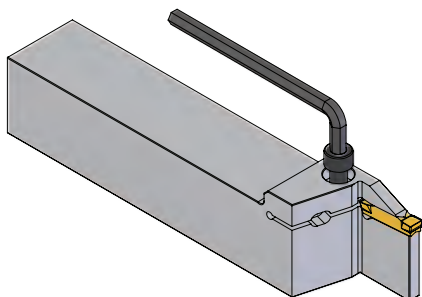

2 Place the same key in the "pocket." Turn and hold the key to loosen the pocket and remove the insert. Place the new insert in the pocket.

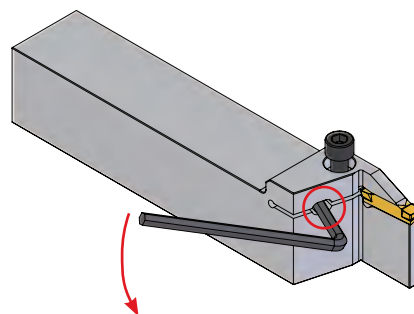

3 Now remove the key from the pocket and secure the insert by firmly locking the top screw.

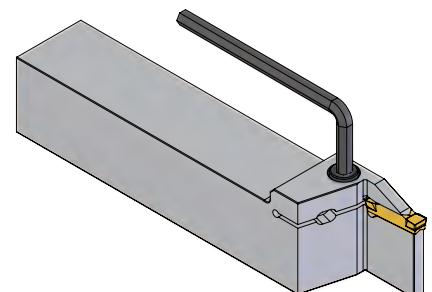

External Monoblock Tools for Grooving, Parting Off, Turning & Threading | INCH

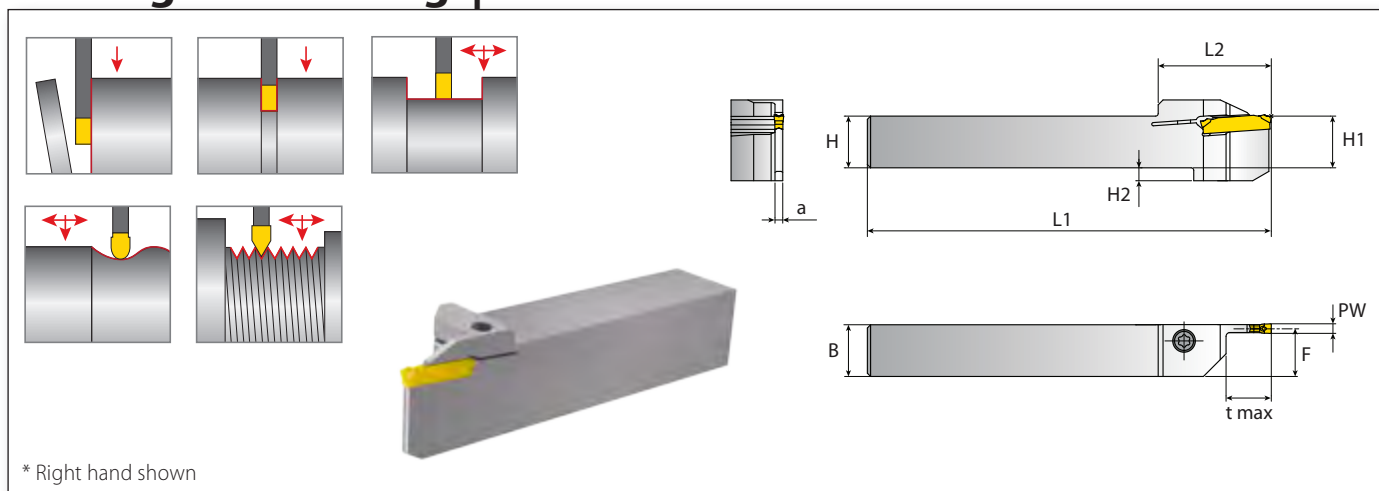

Inch Holders

Ordering Code										Dimensions inch		Spare Parts	
RH/LH	PW	t max	HXB	H1	F	L1	L2	a	H2	Cylindrical Screw	Key		
VGER/L0625-2T12	.079	.472	.625X.625	.625	.597	5	1.38	.06	.162	SM4.0X16-T20	K6T		
VGER/L075-2T12			.750X.750	.750	.722	5	1.38	.06	---	SM4.0X18-T20			
VGER/L050-3T12	.118	.472	.500X.500	.500	.452	5	1.38	.09	.130	SM4.0X16-T20			
VGER/L0625-3T12			.625X.625	.625	.578	5	1.38	.09	.162	SM4.0X18-T20			
VGER/L075-3T12			.750X.750	.750	.703	5	1.38	.09	---				
VGER/L100-3T12			1.00X1.00	1.000	.953	5	1.38	.09	---				
VGER/L0625-3T21			.625X.625	.625	.578	5	1.38	.09	.162				
VGER/L075-3T21			.750X.750	.750	.703	5	1.38	.09	---				
VGER/L100-3T21	1.00X1.00	1.000	.953	5	1.38	.09	---						
VGER/L0625-4T21	.157	.827	.625X.625	.625	.567	5	1.38	.116	.162	SM4.0X18-T20			
VGER/L075-4T21			.750X.750	.750	.692	5	1.38	.116	---				
VGER/L100-4T21			1.00X1.00	1.000	.942	5	1.38	.116	---				

NEW

Reinforced Monoblock Tools for Parting, Grooving & Threading

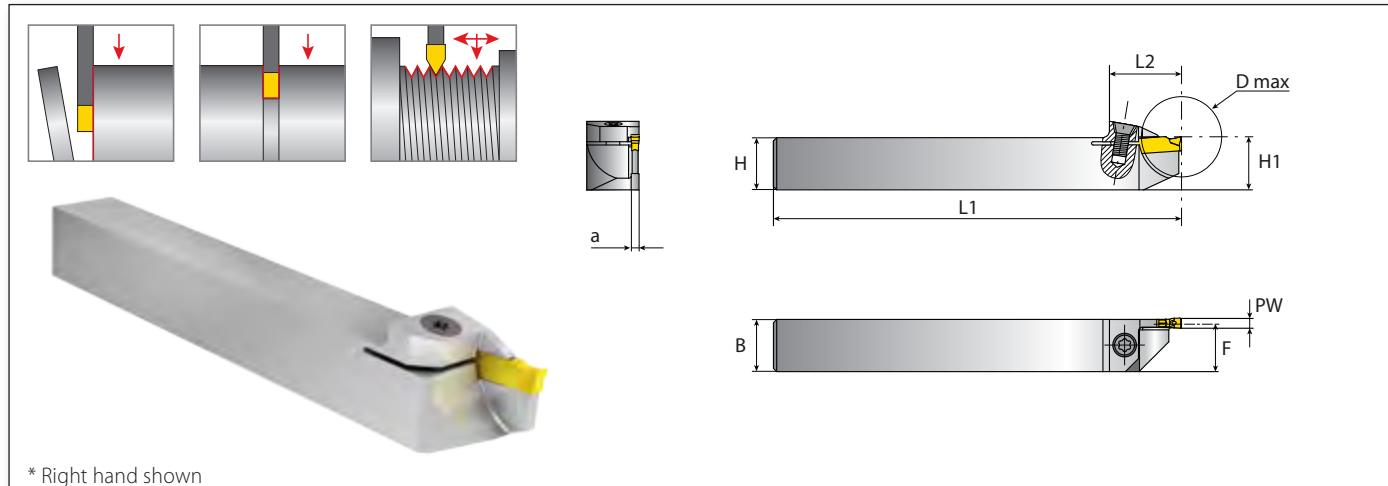

* Right hand shown

Metric Holders

Ordering Code									Dimensions mm		Spare Parts	
RH/LH	PW	D max	HXB	H1	F	L1	L2	a				
VGER/L1212-2T12PH	2	26	12X12	12	11.3	125	22	1.4	SCM4X14	KT-15		
VGER/L1616-2T12PH		26	16X16	16	15.3	125	22	1.4				
VGER/L2020-2T12PH		26	20X20	20	19.3	125	22	1.4				
VGER/L2525-2T21PH		42	25X25	25	24.3	125	30	1.4				
VGER/L1616-3T12PH	3	26	16X16	16	14.8	125	22	2.4				
VGER/L2020-3T21PH		42	20X20	20	18.8	125	30	2.4				
VGER/L2525-3T21PH		42	25X25	25	23.8	125	30	2.4				

Inch Holders

Ordering Code									Dimensions inch		Spare Parts	
RH/LH	PW	D max	HXB	H1	F	L1	L2	a				
VGER/L050-2T12PH	0.079	1.02	.500X.500	.500	.472	5.0	.87	.06	SCM4X14	KT-15		
VGER/L0625-2T12PH		1.02	.625X.625	.625	.597	5.0	.87	.06				
VGER/L075-2T12PH		1.02	.750X.750	.750	.722	5.0	.87	.06				
VGER/L100-2T21PH		1.65	1.00X1.00	1.000	.972	5.0	1.18	.06				
VGER/L0625-3T12PH	0.118	1.02	.625X.625	.625	.578	5.0	.87	.09				
VGER/L075-3T21PH		1.65	.750X.750	.750	.703	5.0	1.18	.09				
VGER/L100-3T21PH		1.65	1.00X1.00	1.000	.953	5.0	1.18	.09				

Blades for Grooving & Parting Off

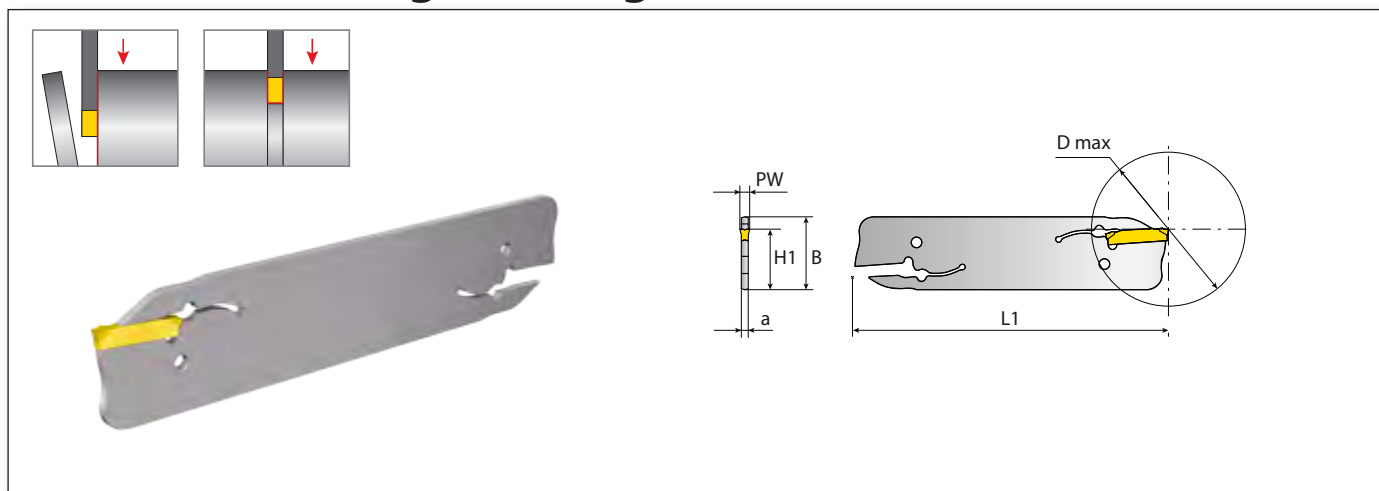

Spare Parts

Ordering Code	Dimensions mm / inch						
	B	PW	D max*	H1	L1	a	Key
VGP26-2D	26 / 1.024	2 / .079	50 / 1.969	21.4 / .843	110 / 4.331	1.4 / .055	VP-3
VGP26-3D	26 / 1.024	3 / .118	70 / 2.756	21.4 / .843	110 / 4.331	2.4 / .094	VP-3
VGP32-3D	32 / 1.260		100 / 3.937	24.8 / .976	150 / 5.906	2.4 / .094	
VGP35-3S	35 / 1.378		100 / 3.937	33.5 / 1.319	150 / 5.906	2.4 / .094	
VGP32-4D	32 / 1.260	4 / .157	100 / 3.937	24.8 / .976	150 / 5.906	3.0 / .118	VP-4
VGP32-5D	32 / 1.260	5 / .197	100 / 3.937	24.8 / .976	150 / 5.906	4.0 / .157	VP-G
VGP32-6D	32 / 1.260	6 / .236	100 / 3.937	24.8 / .976	150 / 5.906	5.0 / .197	

* D max figures presented are for single sided insert (VGS)

Reinforced Blades for Grooving & Parting Off

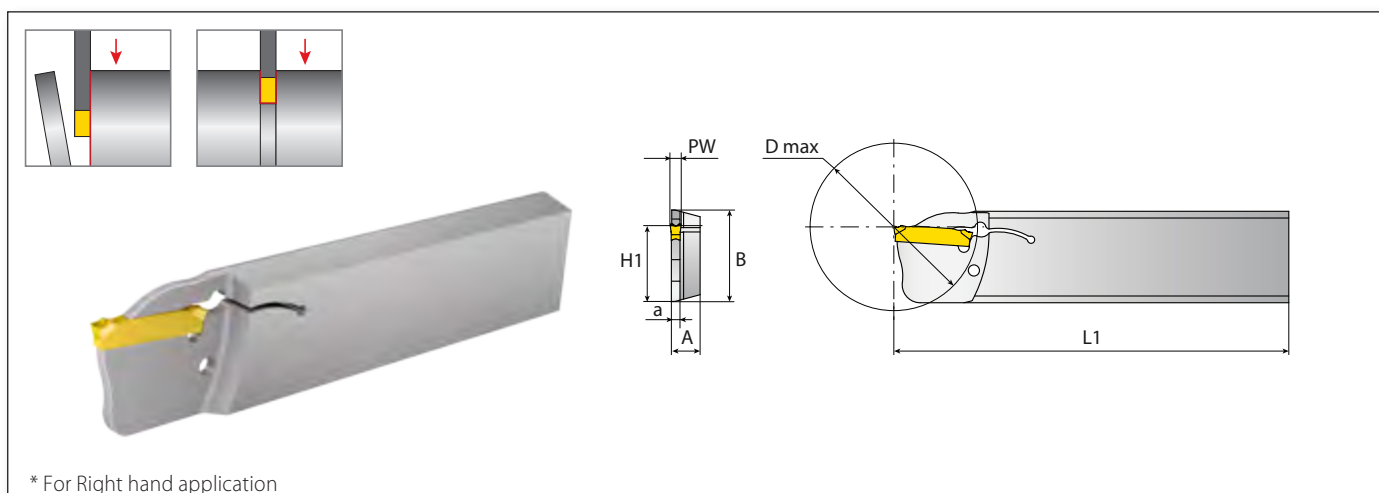

* For Right hand application

Spare Parts



Ordering Code	Dimensions mm / inch							
RH/LH	B	PW	D max*	H1	L1	A	a	Key
VGWR/L26-2S	26 / 1.024	2 / .079	50 / 1.969	21.4 / .834	110 / 4.331	8.0 / .315	1.4 / .055	VP-3
VGWR/L26-3S	26 / 1.024	3 / .118	50 / 1.969	21.4 / .834	110 / 4.331	8.0 / .315	2.4 / .094	

* D max figures presented are for single sided insert (VGS)

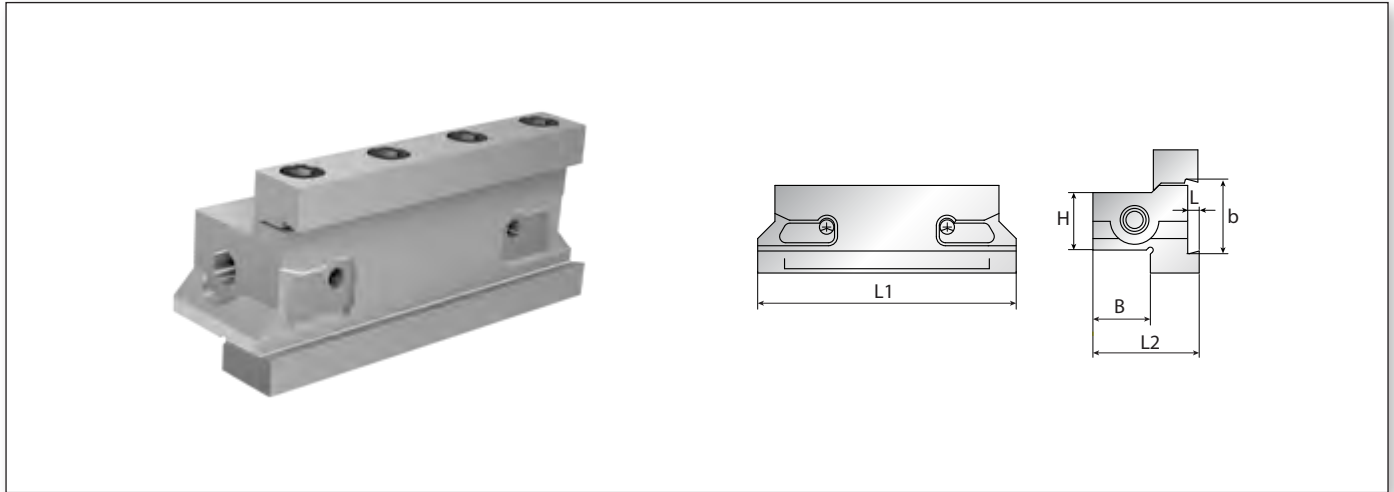

Blade Holders



Metric Holders

Ordering Code		Dimensions mm					Spare Parts	
	b	H	B	L	L1	L2		
VBA 2020-26	26	20	20	4	90	37	Cylindrical Screw	Key
VBA 2520-32	32	25	20	5.2	110	37.7	M6x1.0x25	K5

Inch Holders

Ordering Code		Dimensions inch					Spare Parts	
	b	H	B	L	L1	L2		
VBA 075-26	1.024	.75	.787	.157	3.543	1.457	Cylindrical Screw	Key
VBA 100-32	1.260	1.00	1.020	.205	4.331	1.727	M6x1.0x25	K5

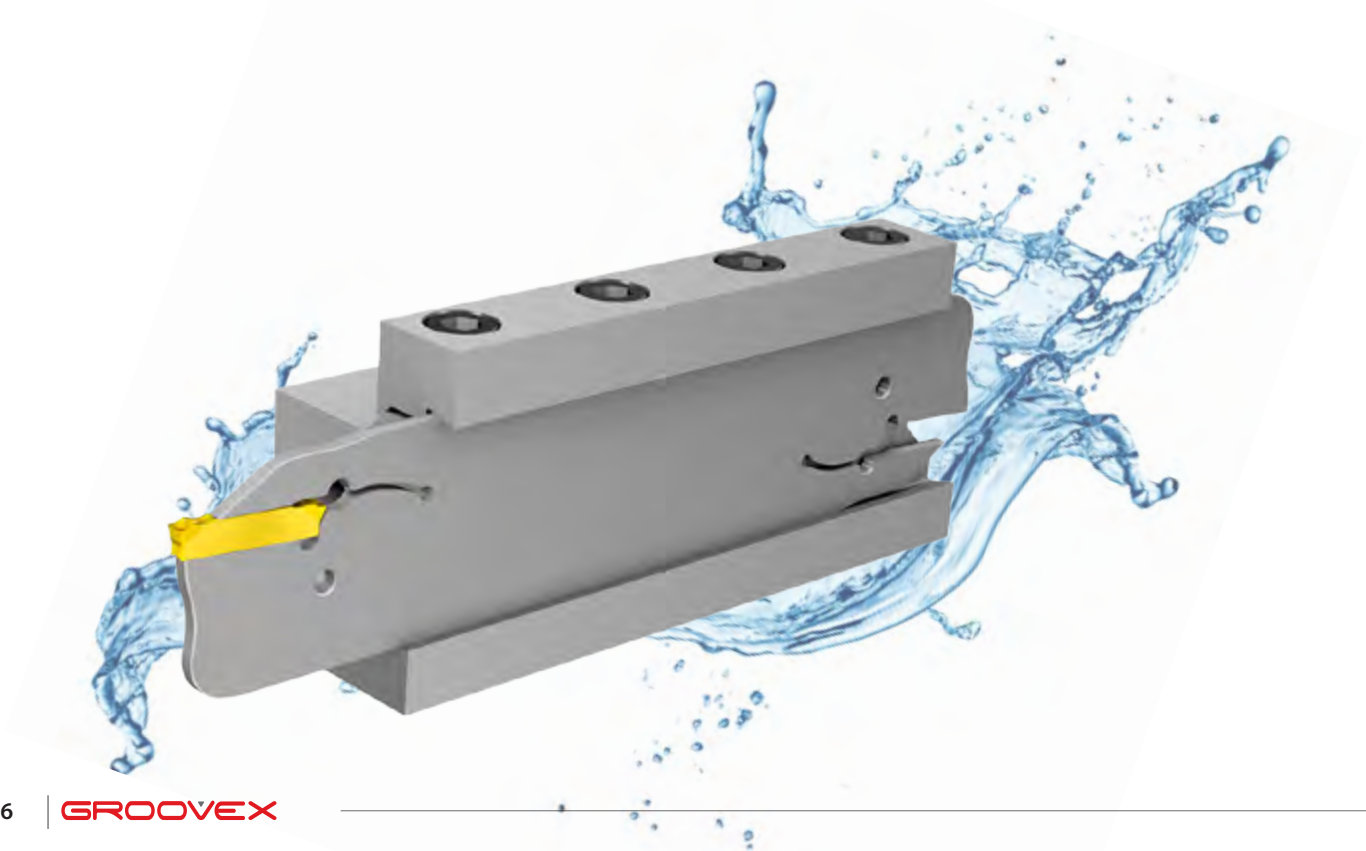

Modules for Grooving, Parting Off & Turning

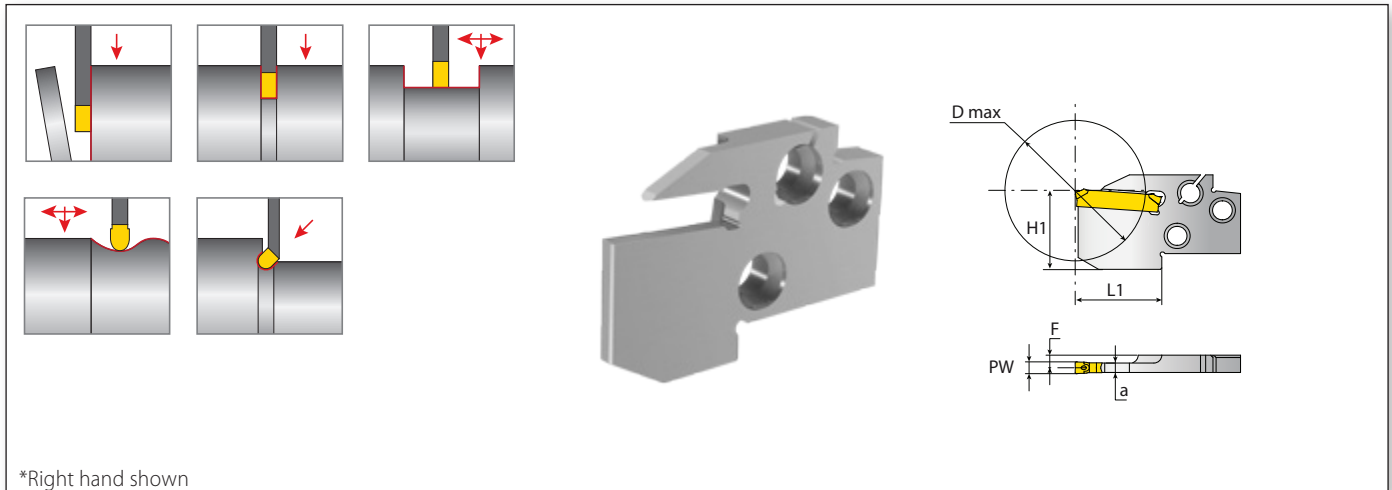

Ordering Code		Dimensions mm / inch				
RH/LH	PW	D max	H1	F	L1	a
VGAR/L20T25-2S	2 / .079	40 / 1.575	20 / .787	3.7 / .146	22 / .866	1.4
VGAR/L20T25-3S	3 / .118	40 / 1.575	20 / .787	3.2 / .126	24 / .945	2.4
VGAR/L20T25-4S	4 / .157	44 / 1.732	20 / .787	2.9 / .114	24 / .945	3.0
VGAR/L25T25-2S	2 / .079	40 / 1.575	25 / .984	5.2 / .205	22 / .866	1.4
VGAR/L25T25-3S	3 / .118	40 / 1.575	25 / .984	4.7 / .185	24 / .945	2.4
VGAR/L25T25-4S	4 / .157	44 / 1.732	25 / .984	4.4 / .173	24 / .945	3.0

Depth of Groove in Relation to Workpiece Diameter (00° - 90°)

Dimensions mm / inch	
D max	t max
50 / 1.969	20.0 / .787
100 / 3.937	17.0 / .669
150 / 5.906	16.0 / .630
200 / 7.874	15.2 / .598

Modular Bodies for Grooving, Parting Off & Turning | METRIC

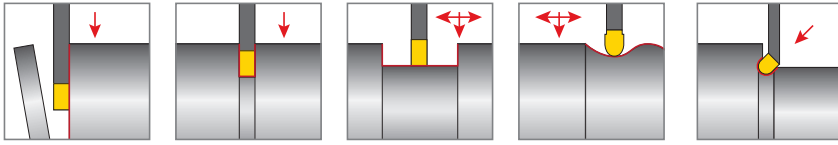

* Right hand shown

Spare Parts

Ordering Code		Dimensions mm							
RH/LH	H/H1	B	B1	H2	F	L1	L2	Conical Screw	Key
VBMR/L2020-00	20	20.0	24.3	24	20.15	110	20	SM4x14 T15	TK-T15
VBMR/L2525-00	25	25.0	31.0	30	25.50	140	25	SM5x18 T20	TK-T20

* Right hand shown

Spare Parts

Ordering Code		Dimensions mm							
RH/LH	H/H1	B	H2	L1	L2			Conical Screw	Key
VBMR/L2020-90	20	20.0	24	110	20			SM4x14 T15	TK-T15
VBMR/L2525-90	25	25.0	30	140	28			SM5x18 T20	TK-T20

I For 90° Right-hand Tool: Use right-hand body with left-hand module

* Left hand shown

Spare Parts

Ordering Code		Dimensions mm							
RH/LH	H/H1	B	B1	H2	L1	L2	F	Conical Screw	Key
VBMR/L2020-45	20	20.0	21.5	24	110	20	14.5	SM4x10.5 T15 SM4x14 T15	TK-T15
VBMR/L2525-45	25	25.0	26.0	30	140	25	18	SM5x13.5 T20 SM5x18 T20	TK-T20

I For 45° Right-hand Tool: Use right-hand body with left-hand module

Modular Bodies for Grooving, Parting Off & Turning | INCH

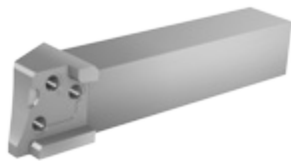
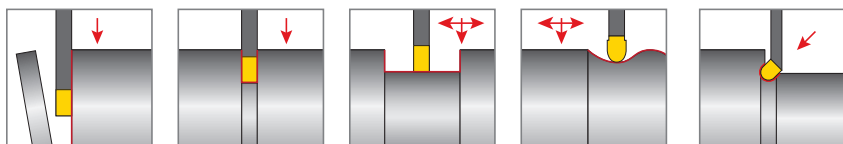

* Right hand shown

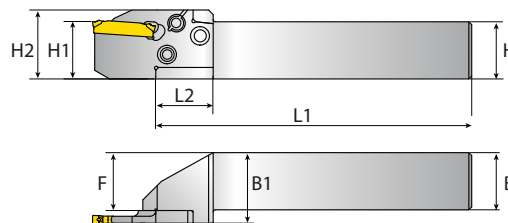

Spare Parts

Ordering Code		Dimension <i>inch</i>							
RH/LH	H/H1	B	B1	H2	F	L1	L2	Conical Screw	Key
VBMR/L075-00	.75	.75	.957	.984	.793	4.5	.787	SM4x14 T15	TK-T15
VBMR/L100-00	1.00	1.00	1.236	1.197	1.020	5.5	.984	SM5x18 T20	TK-T20

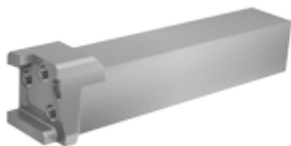

* Right hand shown

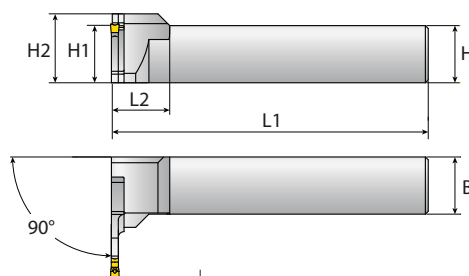

Spare Parts

Ordering Code		Dimensions <i>inch</i>						
RH/LH	H/H1	B	H2	L1	L2	Conical Screw	Key	
VBMR/L075-90	.75	.75	.907	4.5	.787	SM4x14T15	TK-T15	
VBMR/L100-90	1.00	1.00	1.197	5.5	1.000	SM5x18T20	TK-T20	

! For 90° Right-hand Tool: Use right-hand body with left-hand module

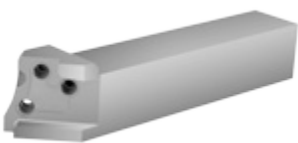

* Left hand shown

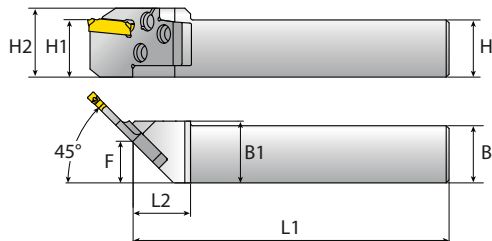

Spare Parts



Ordering Code		Dimensions <i>inch</i>							
RH/LH	H/H1	B	B1	H2	L1	L2	F	Conical Screw	Key
VBMR/L075-45	.75	.75	.846	.984	4.5	.787	.571	SM4x10.5 T15 SM4x14 T15	TK-T15
VBMR/L100-45	1.00	1.00	1.024	1.197	5.5	.984	.709	SM5x13.5 T20 SM5x18 T20	TK-T20

! For 45° Right-hand Tool: Use right-hand body with left-hand module

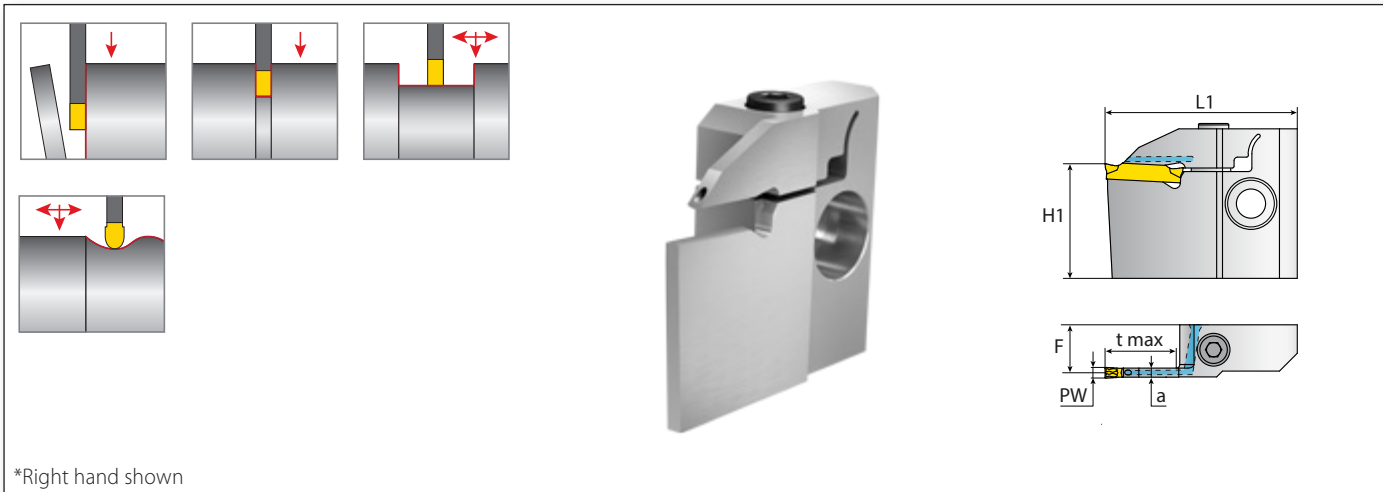
Radial Grooving Modules with High Pressure Coolant Thru NEW



*Right hand shown

Ordering Code							Dimensions mm		Spare Parts	
RH/LH	PW	t max	H1	F	L1	a				
VGAR/L-T09-2C	2	9	32	13.9	43	1.58	SM5X16	K4H		
VGAR/L-T18-2C	2	18	32	13.9	52	1.58				
VGAR/L-T10-3C	3	10	32	13.3	44	2.48				
VGAR/L-T20-3C	3	20	32	13.3	54	2.48				
VGAR/L-T12-4C	4	12	32	13.0	46	3.10				
VGAR/L-T24-4C	4	24	32	13.0	58	3.10				
VGAR/L-T15-5C	5	15	32	13.5	49	4.00				
VGAR/L-T30-5C	5	30*	32	12.5	64	4.00				
VGAR/L-T20-6C	6	20	32	13.0	54	5.00				
VGAR/L-T40-6C	6	40*	32	13.0	74	5.00				

* T max figures presented for single sided inserts (VGS).

Mounting and Replacing Inserts for Radial and Face Grooving Modules with High Pressure Coolant Thru:

1 Unlock the top screw using the key provided.

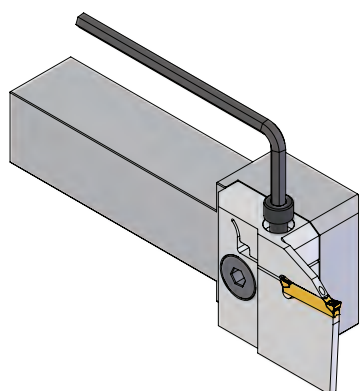

2 Place the same key in the "pocket." Turn and hold the key to loosen the pocket and remove the insert. Place the new insert in the pocket.

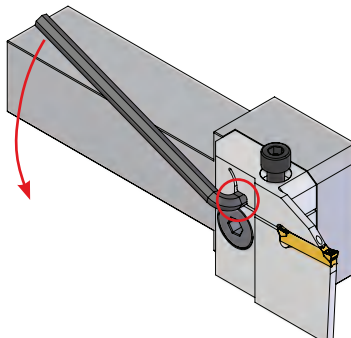

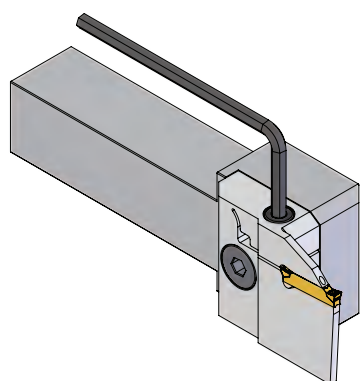

3 Now remove the key from the pocket and secure the insert by firmly locking the top screw.



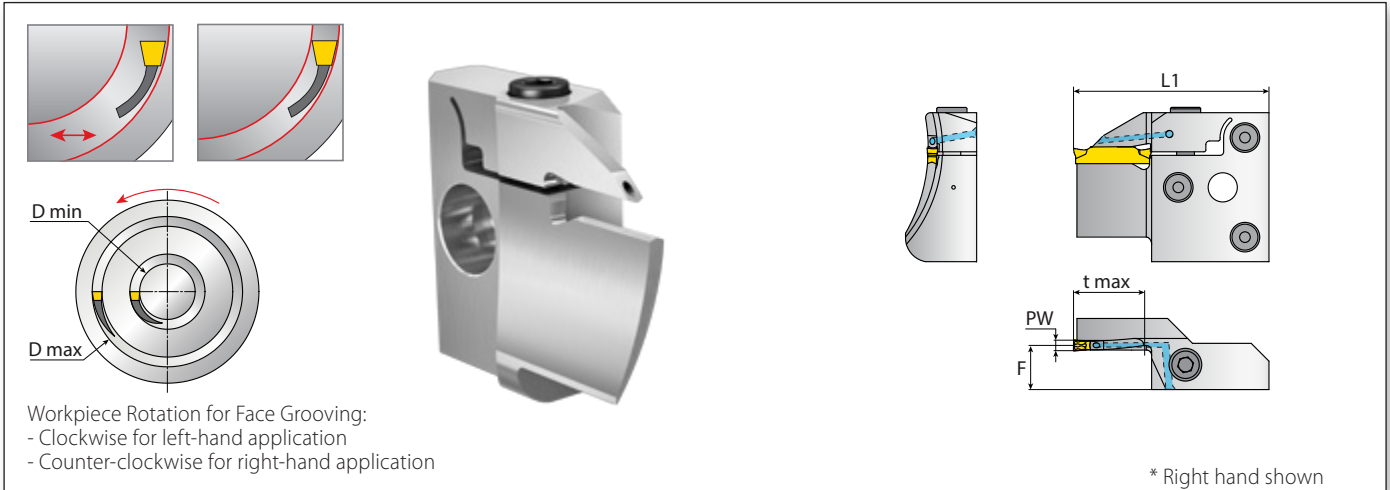

Face Grooving Modules with High Pressure Coolant Thru

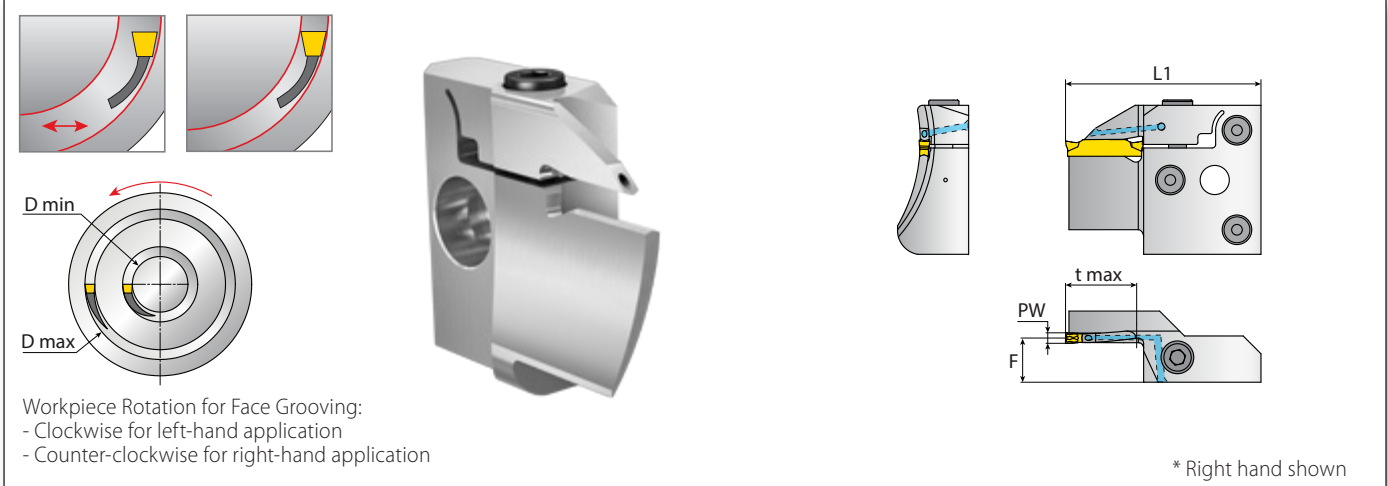

Ordering Code							Dimensions mm		Spare Parts					
RH/LH	PW	t max	D min	D max	F	L1								
							Screw	Key						
VGFR/L-2530-T10-3C	3	10	25	30	12.5	45								
VGFR/L-3038-T10-3C			30	38										
VGFR/L-3848-T10-3C			38	48										
VGFR/L-4860-T10-3C			48	60										
VGFR/L-6075-T10-3C			60	75										
VGFR/L-75100-T10-3C			75	100										
VGFR/L-100200-T10-3C			100	200										
VGFR/L-6075-T20-3C	20	20	60	75	12	55	SM5X16	K4H						
VGFR/L-75100-T20-3C			75	100										
VGFR/L-100200-T20-3C			100	200										
VGFR/L-3048-T12-4C	4	12	30	48	12	47	SM5X16	K4H						
VGFR/L-4860-T12-4C			48	60										
VGFR/L-6075-T12-4C			60	75										
VGFR/L-75100-T12-4C			75	100										
VGFR/L-100150-T12-4C			100	150										
VGFR/L-150->-T12-4C			150	>150										
VGFR/L-3048-T24-4C			24	24					30	48	13.5	60	SM5X16	K4H
VGR/LF-4860-T24-4C	48	60												
VGFR/L-6075-T24-4C	60	75												
VGFR/L-75100-T24-4C	75	100												
VGFR/L-100150-T24-4C	5	22	100	150	13.5	60	SM5X16	K4H						
VGFR/L-150->-T24-4C			150	>150										
VGFR/L-4255-T22-5C			22	22					42	55	13.5	60	SM5X16	K4H
VGFR/L-5575-T22-5C									55	75				
VGFR/L-75130-T22-5C			45	45					75	130	13.5	92	SM5X16	K4H
VGFR/L-130200-T22-5C	130	200												
VGFR/L-200->-T22-5C	200	>200												
VGFR/L-130200-T45-5C	45	45	130	200	13.5	92	SM5X16	K4H						
VGFR/L-200400-T45-5C			200	400										
VGFR/L-450->-T45-5C	450	>450												

Face Grooving Modules with High Pressure Coolant Thru (con't) NEW



Ordering Code							Spare Parts	
Dimensions mm								
RH/LH	PW	t max	D min	D max	F	L1	Screw	Key
VGFR/L-4255-T22-6C	6	22	42	55	13	60	SM5X16	K4H
VGFR/L-5575-T22-6C			55	75				
VGFR/L-75130-T22-6C			75	130				
VGFR/L-130200-T22-6C			130	200				
VGFR/L-200->-T22-6C		200	>200					
VGFR/L-130200-T45-6C		45	92	130		200		
VGFR/L-200400-T45-6C				200		400		
VGFR-450->-T45-6C	450			>450				



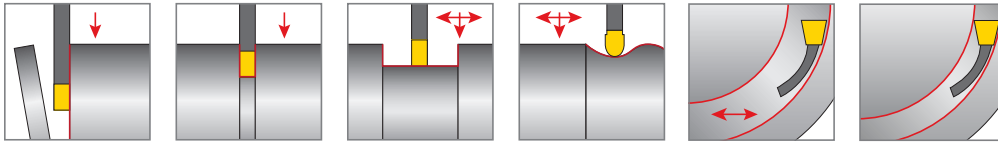

Modular Bodies with High Pressure Coolant Thru for Grooving, Face Grooving, Parting Off and Turning



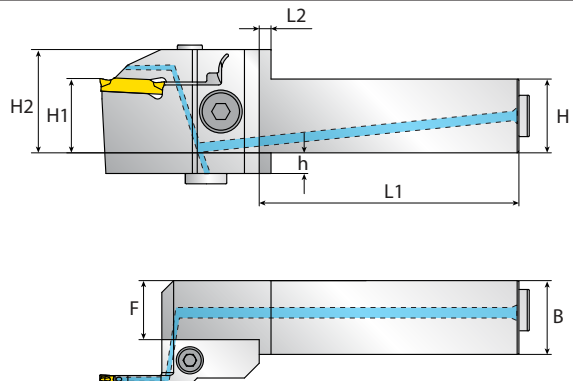





* Right hand shown * Right hand assembly

Ordering Code	Dimensions mm							Spare Parts	
	H/H1	B	H2	h	F	L1	L2		
VBMR/L2020-00-C	20	20	30	12	15	106	4	SM8x25	K6H
VBMR/L2525-00-C	25	25	35	7	20	121	4		
VBMR/L3225-00-C	32	25	42	0	20	136	4		

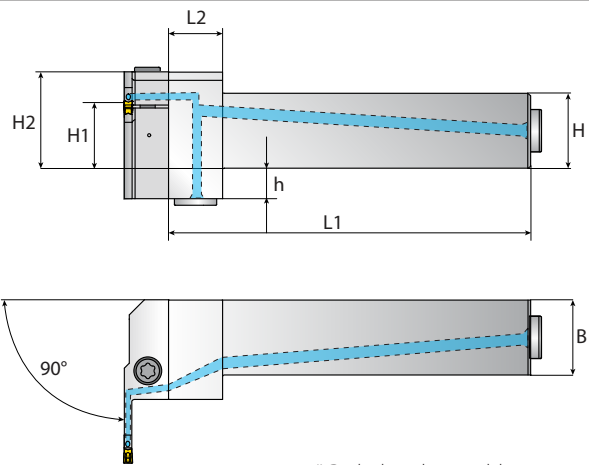





* Right hand shown * Right hand assembly

Ordering Code	Dimensions mm							Spare Parts	
	RH/LH	H/H1	B	H2	h	L1	L2		
VBMR/L2020-90-C		20	20	30	12	111	18	SM8x25	K6H
VBMR/L2525-90-C		25	25	35	7	120	18		
VBMR/L3225-90-C		32	25	42	0	130	18		

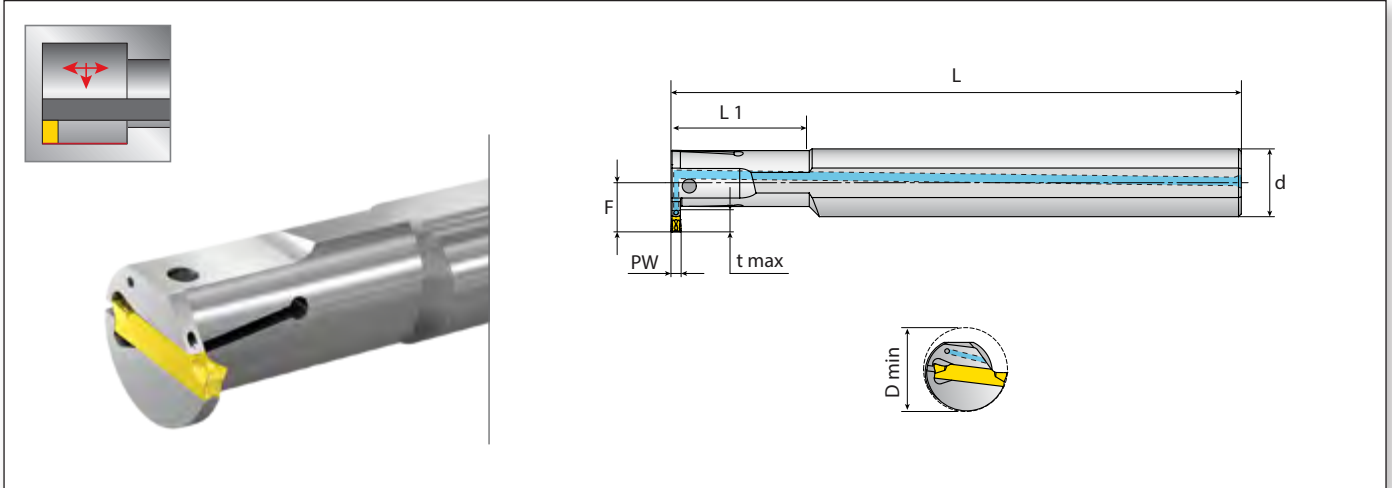
Internal Grooving & Turning NEW



Ordering Code		Dimensions mm						Spare Parts	
RH/LH	PW	t max	L1	D min	d	F	L		
VGIR/L-20-25-2C	2	7	40.5	25	20	14.5	180	SM5x12	K4H
VGIR/L-25-32-2C		9	50.5	32	25	18.0	200		
VGIR/L-20-25-3C	3	7	40.5	25	20	14.4	180	SM5x16	
VGIR/L-25-32-3C		9	50.5	32	25	18.0	200		
VGIR/L-20-28-4C	4	9	41.0	28	20	16.5	180	SM5x12	
VGIR/L-25-32-4C		9	51.0	32	25	18.0	200		



Technical Data

Recommended Cutting Speeds

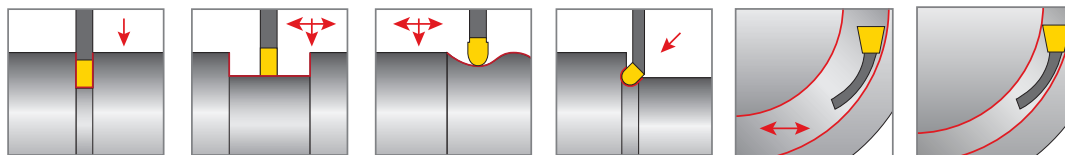

Vc [m/min] for Grooving and Turning

Material Group	Vargus No.	Material	Hardness Brinell HB	Carbide Grade			
				VMG PVD M35	VPG PVD P20	VKG CVD K25	
P Steel	1	Unalloyed Steel	Low Carbon (C=0.1-0.25%)	125	100-160	120-260	120-280
	2		Medium Carbon (C=0.25-0.55%)	150	80-140	90-220	90-250
	3		High Carbon (C=0.55-0.85%)	170	80-140	90-220	90-250
	4	Low Alloy Steel (alloying elements ≤5%)	Non Hardened	180	80-140	90-220	90-250
	5		Hardened	275	50-120	60-150	60-180
	6	High Alloy Steel (alloying elements >5%)	Hardened	350	40-70	50-100	60-160
	7		Annealed	200	50-100	90-150	90-250
	8	Cast Steel	Hardened	325	40-70	50-100	60-160
	9		Low Alloy (alloying elements <5%)	200	50-100	90-150	90-250
	10	High Alloy (alloying elements >5%)	225	50-100	60-150	60-180	
M Stainless Steel	11	Stainless Steel Ferritic	Non Hardened	200	50-80	60-160	
	12		Hardened	330	40-80	50-140	
	13	Stainless Steel Austenitic	Austenitic	180	50-80	60-160	
	14		Super Austenitic	200	50-80	60-160	
	15	Stainless Steel Cast Ferritic	Non Hardened	200	50-80	60-160	
	16		Hardened	330	40-80	50-140	
	17	Stainless Steel Cast Austenitic	Austenitic	200	50-80	60-160	
	18		Hardened	330	40-80	50-140	
K Cast Iron	28	Malleable Cast Iron	Ferritic (short chips)	130		160-200	160-280
	29		Pearlitic (long chips)	230		140-220	140-260
	30	Grey Cast Iron	Low Tensile Strength	180		160-200	160-280
	31		High Tensile Strength	260		100-200	100-240
	32	Nodular Sg Iron	Ferritic	160		100-200	100-240
	33		Pearlitic	260		100-200	100-240
N(K) Non-Ferrous Metals	34	Aluminium Alloys Wrought	Non Aging	60	150-300		
	35		Aged	100	150-250		
	36	Aluminium Alloys	Cast	75	150-300		
	37		Cast & Aged	90	150-300		
	38	Aluminium Alloys	Cast Si 13-22%	130	150-250		
	39	Copper and Copper Alloys	Brass	90	150-300		
40	Bronze And Non Leaded Copper		100	150-300			
S(M) Heat Resistant Material	19	High Temperature Alloys	Annealed (iron based)	200	25-40	30-50	
	20		Aged (iron based)	280	25-35	20-50	
	21		Annealed (nickel or cobalt based)	250	25-35	20-50	
	22		Aged (nickel or cobalt based)	350	25-35	20-50	
	23	Titanium Alloys	Pure 99.5 Ti	400Rm	25-40	30-50	
24	α+β Alloys		1050Rm	25-60	30-70		
H(K) Hardened Material	25	Extra Hard Steel	Hardened & Tempered	45-50HRc		20-40	30-50
	26			51-55HRc		15-30	25-45

Vc [m/min] for Parting Off

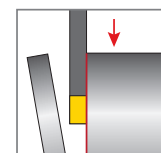

For Parting Off and to also improve chip forming and chip evacuation; **reduce speed by ≈ 30%.**

For Gummy materials, such as stainless steel and heat resistant metals - or in case of build up on edge (cold welding) - **speed should be increased by ≈ 20%.**

Feed Rate (f) Starting Point for Deep Grooving, Face Grooving & Parting Off

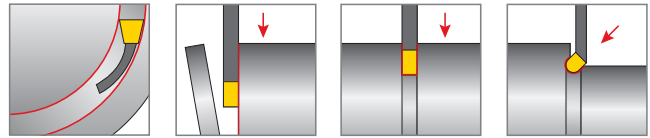

2.0 mm Insert Width

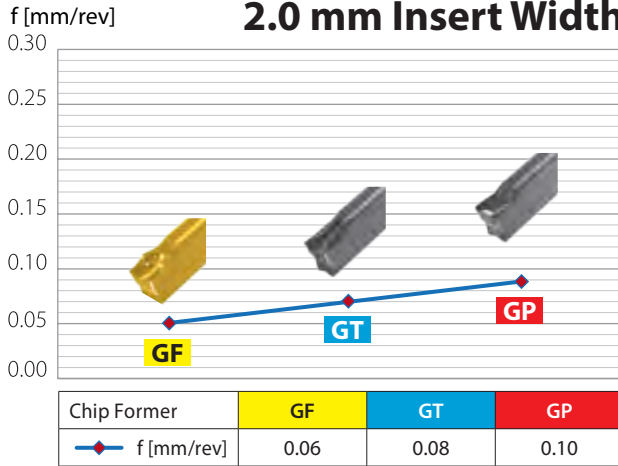

3.0 mm Insert Width

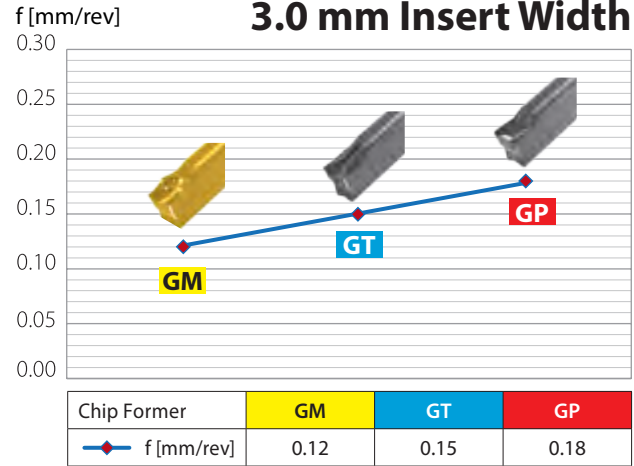

4.0 mm Insert Width

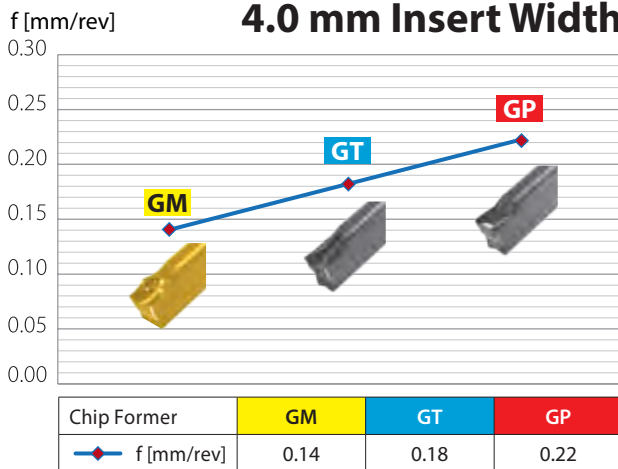

5.0 mm Insert Width

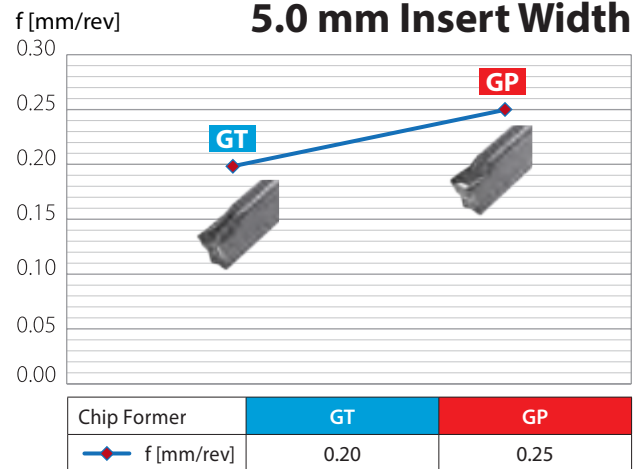

6.0 mm Insert Width

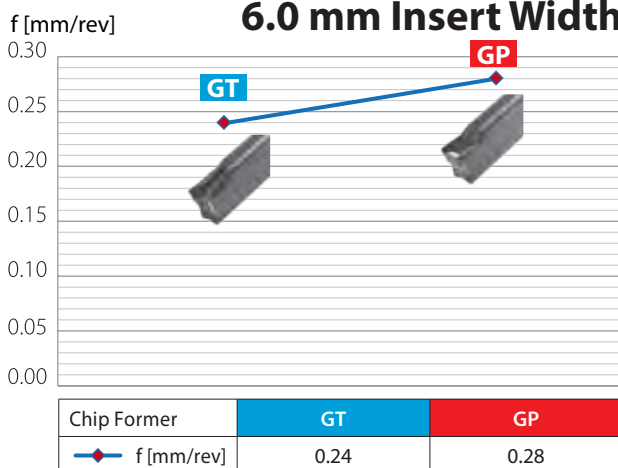

Correct chip forming is essential for chip evacuation. Low feed rates with sufficient chip evacuation improves process stability and tool life. Feed rate should be increased only when improved evacuation is needed to prevent wall scratching or chip entanglement.

For Parting Off, it is recommended to reduce feed rate by 30% while using R / L inserts.

For Parting Off, it is strongly recommended to reduce feed rate by 50% as the insert approaches rotation center. Reduce feed when the insert approaches approx. 6.0 mm diameter.

For better chip evacuation in **Face Grooving**, creating short chips is preferable. It is therefore recommended to work in short intervals (pecking), at a maximum grooving depth of twice the insert width. Taking into consideration the workpiece material and groove diameter, it is a highly recommended to begin the first cut at no longer than the insert's width.

Feed Rate (f) and Depth of Cuts for Axial Turning, Profiling and Face Grooving

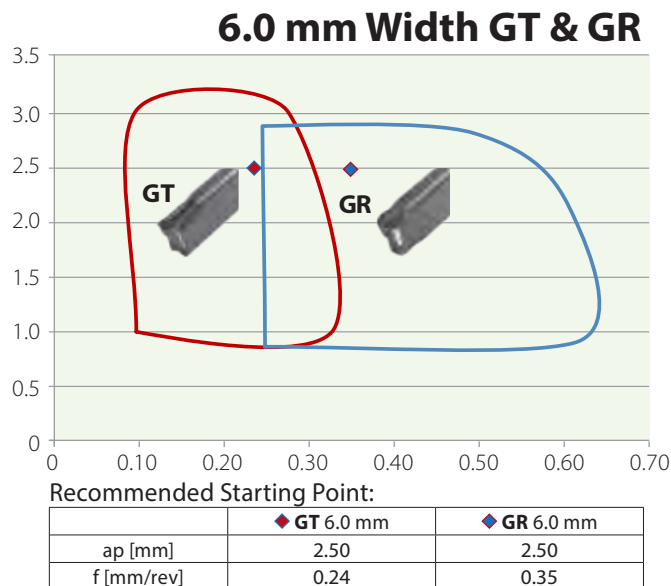
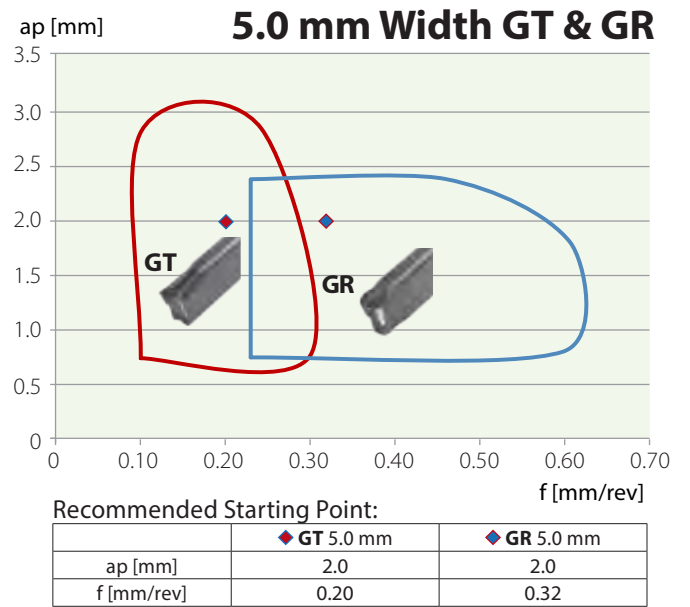
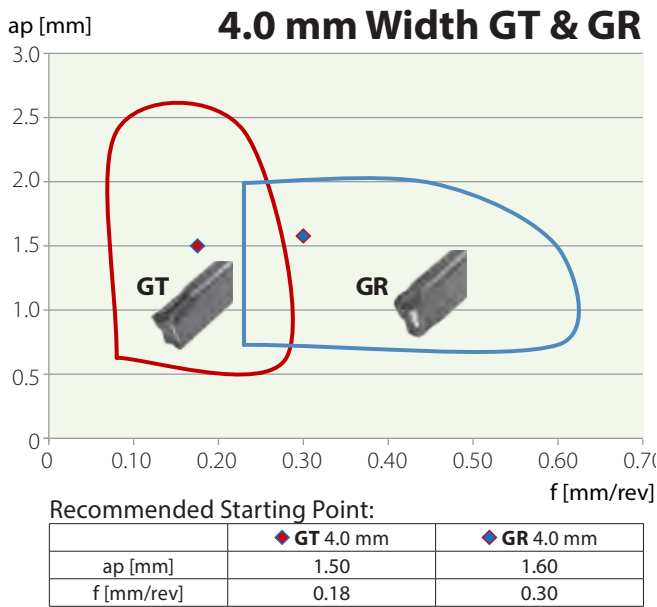
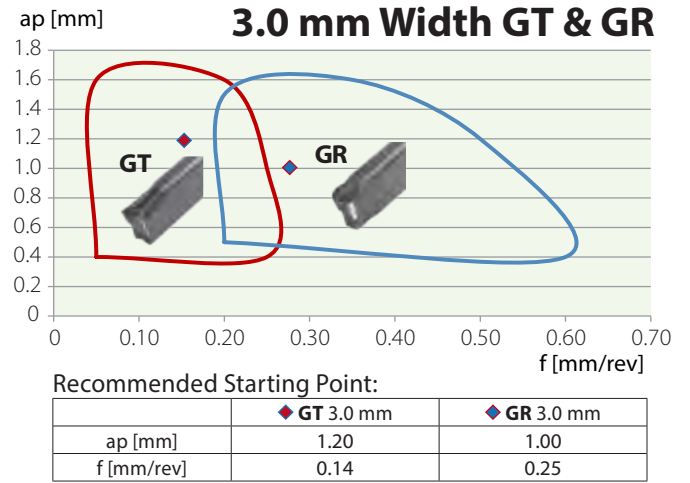
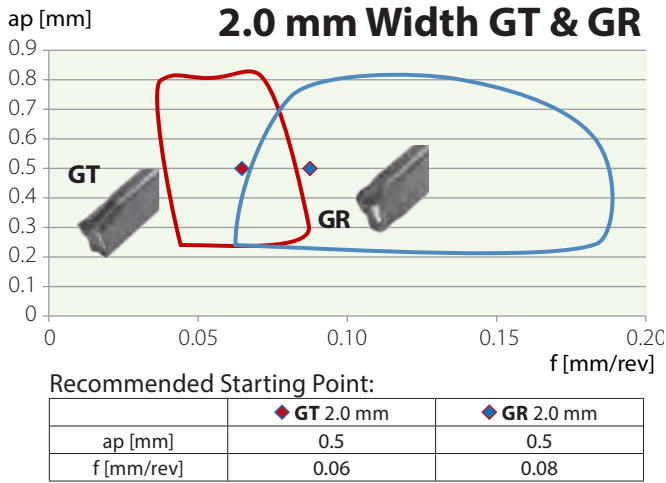
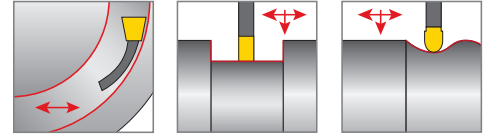

Selecting the Correct Face Grooving Module

VG Cut Ordering Code Example: VGFR-4860-T24-4C

D max

D min

Wrong Support

Correct Support

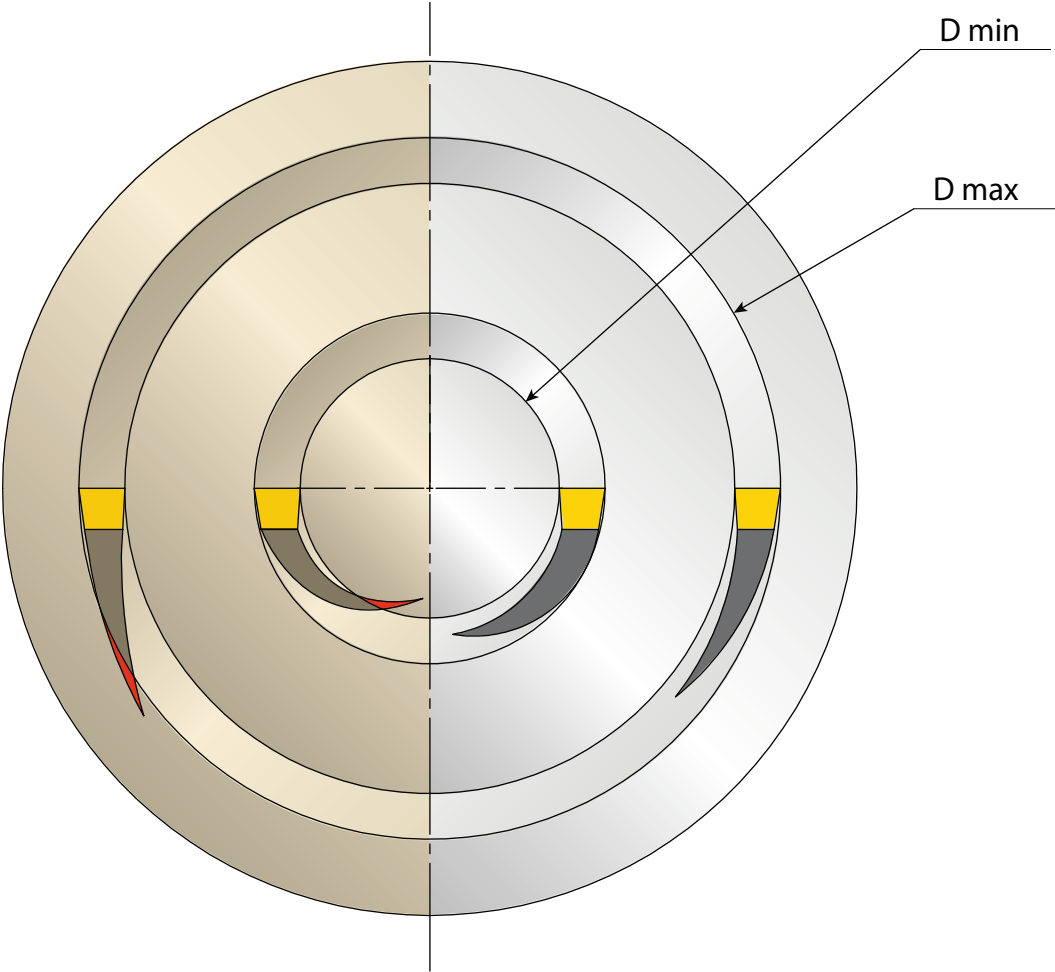

Face Groove and Turn Machining Recommendations:

Roughing:

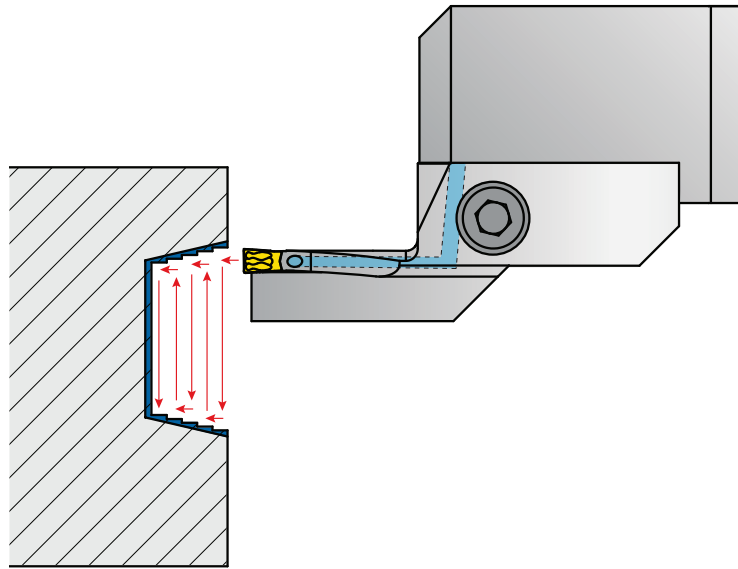

1. Start by grooving close to outer diameter, followed by face turning toward the center.
2. Continue grooving close to inner diameter, followed by face turning away from center. Continue as needed until the workpiece is ready for the finishing operation.
3. The recommended remaining excess material, for the finishing application, should not exceed twice the insert corner radius.

Face Grooving Tips:

- See page 25 for Face Turning cutting speeds.
- See pages 26-27 for Face Grooving cutting data.

Finishing:

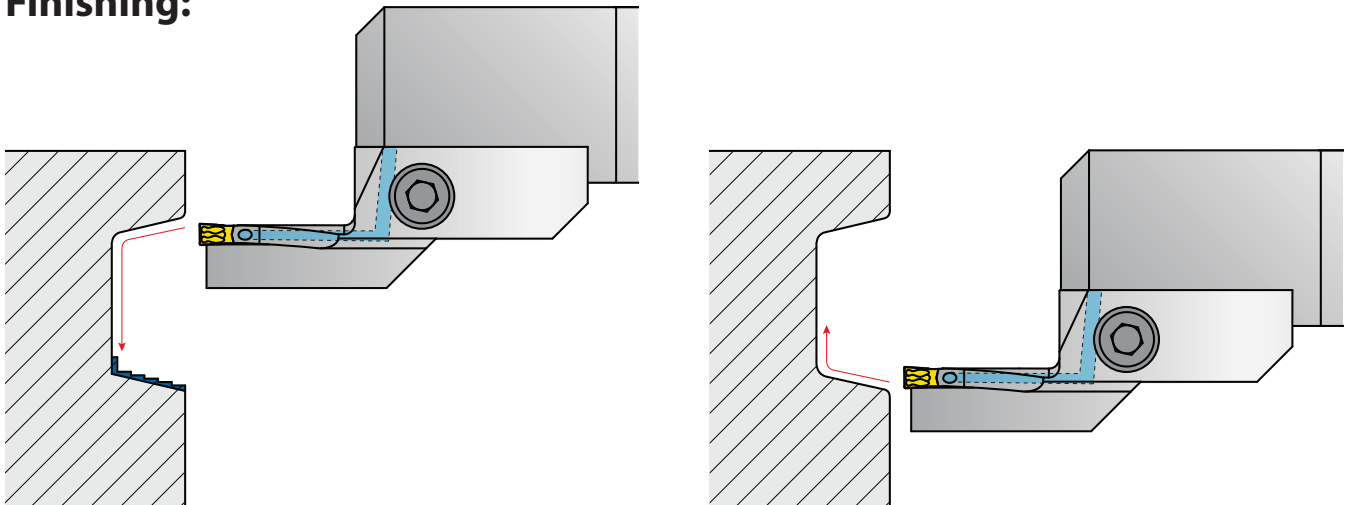

1. Start the Profiling operation from the outer diameter of the workpiece and work in. Generate the desired radius followed by the face turning operation close to the tangential point of the inner radius.
2. Start the Profiling operation from the inner diameter towards the bottom of the workpiece, generate the desired radius as needed.

User Guide for Modular system with high pressure coolant*: Choosing the right Holder for the application (Body + Module):

* For non-coolant Modular system, please see pages 17-19.

Parallel Right Tools

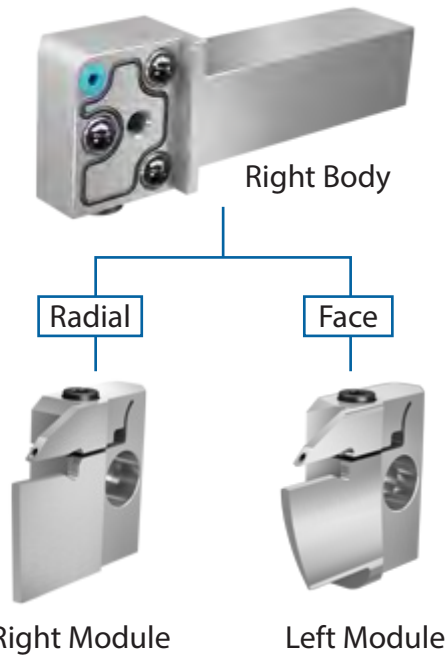

Parallel Left Tools

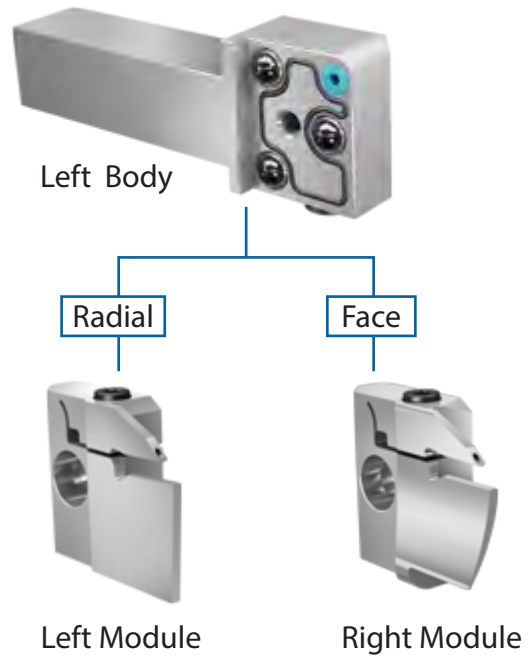

90° Right Tools

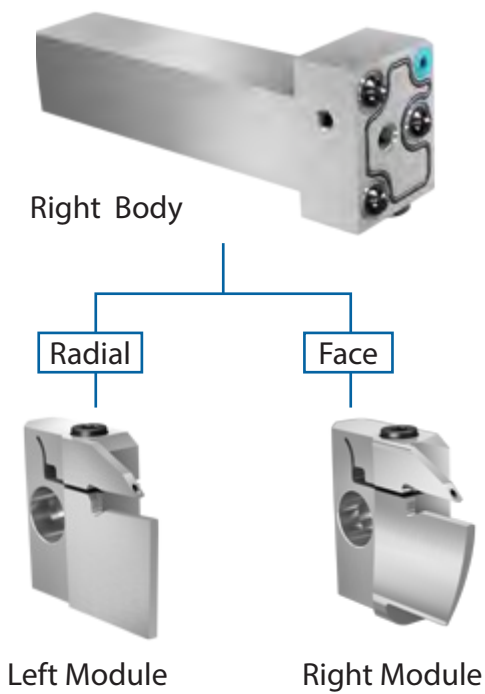

90° Left Tools

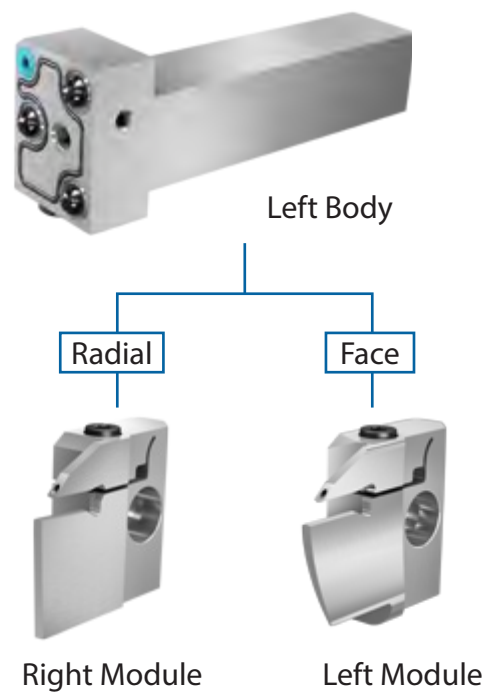

Technical Data

Recommended Cutting Speeds Vc [m/min] for Threading

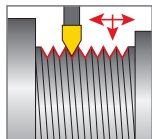

Material Group	Vargus No.	Material	Hardness Brinell HB	Carbide Grade	
				VPG	PVD P20
P Steel	1	Unalloyed Steel	Low Carbon (C=0.1-0.25%)	125	120-260
	2		Medium Carbon (C=0.25-0.55%)	150	90-220
	3		High Carbon (C=0.55-0.85%)	170	90-220
	4	Low Alloy Steel (alloying elements ≤ 5%)	Non Hardened	180	90-220
	5		Hardened	275	60-160
	6		Hardened	350	50-100
	7	High Alloy Steel (alloying elements > 5%)	Annealed	200	90-220
	8		Hardened	325	50-100
	9	Cast Steel	Low Alloy (alloying elements < 5%)	200	90-220
	10		High Alloy (alloying elements > 5%)	225	60-160
M Stainless Steel	11	Stainless Steel Ferritic	Non Hardened	200	60-160
	12		Hardened	330	50-140
	13	Stainless Steel Austenitic	Austenitic	180	60-160
	14		Super Austenitic	200	60-160
	15	Stainless Steel Cast Ferritic	Non Hardened	200	60-160
	16		Hardened	330	50-140
	17	Stainless Steel Cast Austenitic	Austenitic	200	60-160
	18		Hardened	330	50-140
K Cast Iron	28	Malleable Cast Iron	Ferritic (short chips)	130	160-240
	29		Pearlitic (long chips)	230	140-220
	30	Grey Cast Iron	Low Tensile Strength	180	160-240
	31		High Tensile Strength	260	100-200
	32	Nodular Sg Iron	Ferritic	160	100-200
33	Pearlitic		260	100-200	
N(K) Non-Ferrous Metals	34	Aluminium Alloys Wrought	Non Aging	60	200-450
	35		Aged	100	200-350
	36	Aluminium Alloys	Cast	75	200-450
	37		Cast & Aged	90	200-450
	38	Aluminium Alloys	Cast Si 13-22%	130	200-350
	39	Copper and Copper Alloys	Brass	90	200-450
40	Bronze And Non Leaded Copper		100	200-450	
S(M) Heat Resistant Material	19	High Temperature Alloys	Annealed (iron based)	200	30-50
	20		Aged (iron based)	280	20-50
	21		Annealed (nickel or cobalt based)	250	20-50
	22		Aged (nickel or cobalt based)	350	20-50
	23	Titanium Alloys	Pure 99.5 Ti	400Rm	30-50
24	α+β Alloys		1050Rm	30-70	
H(K) Hardened Material	25	Extra Hard Steel	Hardened & Tempered	45-50HRc	20-40
	26			51-55HRc	15-30



VG-Cut

Complete Range of Turning Solutions

GROOVEX

Innovative Grooving & Turning Solutions